

NAUTILUS, NAUTILUS-HD, NAUTILUS-CE

PB45DSL, PB45GAS, PB45LPG,
PB45HDSL, PB45GAS, PB45LPG

Training

Trouble Shooting

Adjustments

Procedures



1	Technical Specifications	Page 4
2	Features	Page 5
3	Safety	Page 6
4	Transporting Machine	Page 13
5	Preventative Maintenance (General)	Page 14
	Lubrication Points	Page 22
	Hydraulic System	Page 24
	Propulsion Pump Neutral Setting	Page 27
	Brush Pattern Adjustments	Page 29
	Squeegee Flare Adjustments	Page 32
	Brakes and Adjustments	Page 35
	Tires	Page 36
	Neutral Sensing Switch	Page 37
	Reverse Sensing Switch	Page 39
6	Troubleshooting	Page 40
7	Adjustments	
	Main Brush & Impeller Pressure Relief	Page 48
	Scrub Brush Floor Pressure	Page 50
	Dual Controller Adjustment for Main Scrub Brush with Optional Side Scrub Brush	Page 52

8	Diagrams	
	Hydraulics	Page 59
	Electrical	Page 90
	Timer/Dip Switch Settings	Page 96
9	Settings and Adjustments	
	Hydraulic Operations and Functions	Page 106
	Squeegee Retaining Plate	Page 129
	Front and Side Brush Skirts	Page 130
	Overhead Guard- Installation	Page 133
	Changing Solid Tires	Page 135

TECHNICAL SPECIFICATIONS

TECHNICAL SPECIFICATIONS

Model Nautilus Rider Scrubber/Sweeper

Model No. PB450DSL, PB450GAS, PB450LPG

General Machine Specifications

Length: 95.00 in
 Width with side scrub brush retracted: . . 60.50 in
 Width with side scrub brush extended: . . 65.50 in
 Height to lowest steering position. 60.50 in
 Height w/overhead guard 83.50 in
 Wheelbase: 47.75 in
 Front tires: 16 in x 6 in molded
 Rear tires: 18 in x 5 in press on
 Aisle width U-turn: 8 ft - 11.7 in
 Empty vehicle weight 3,250 lbs
 Gross vehicle weight 4,800 lbs
 Maximum forward speed: 7.7 mph
 Maximum reverse speed: 4.0 mph
 Maximum climb angle (Traveling): 10 degrees
 Maximum climb angle (Scrubbing): 8 degrees

Scrubbing system

Cleaning path (main brushes) 45 in
 Cleaning path (w/optional side brush) . . 60 in
 Main brush diameter: 12 in
 Main brush length: 45 in
 Main brush speed: 425 RPM
 Main brush force: 200 lb - 400 lb
 Side scrub brush diameter: 16 in
 Side scrub brush speed: 200 RPM
 Solution Tank capacity: 105 gal
 Recovery Tank capacity: 105 gal
 Demister chamber capacity: 17 gal
 (2) Debris trays, total capacity: 2.1 cu ft
 Vacuum fan speed: 11,500 RPM
 Vacuum water lift: 35 in

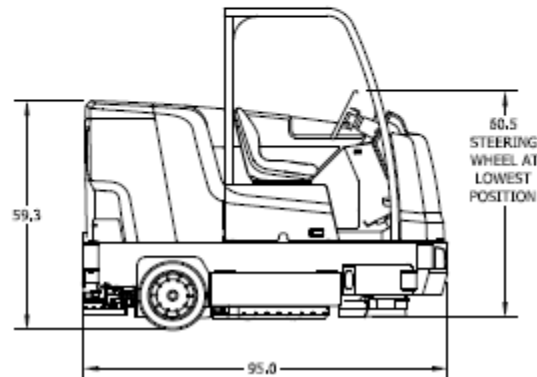
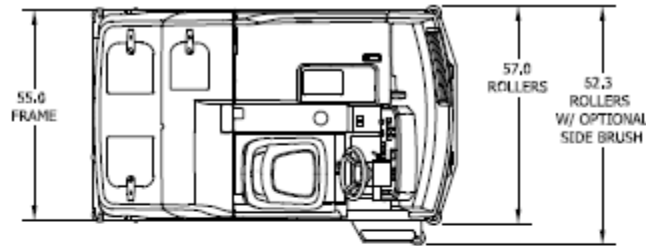

FEATURES

AIR-MOVING SYSTEM

- Internal sound insulation on vacuum impeller
- Engine area shielded from exhaust air, which is vented at the side of the machine

ERGONOMICS SYSTEM

- Roomy, open operator compartment for extra comfort
- Toe operated parking brake
- Adjustable, high-back seat
- Power steering and tilt steering wheel
- Unparalleled maintenance accessibility, hinged sides and covers require no tools.

HYDRAULIC SYSTEM

- Protection for both auxiliary and propulsion pumps using separate 100 mesh suction strainer
- Hydraulic reservoir equipped with site gauge and dip stick for fluid level check and replacement
- Hydraulic filter equipped with color coded pressure gauge to indicate filter replacement

DRIVE-TRAIN SYSTEM

- Industrial liquid-cooled engine
- Heavy-duty radiator & Tri-phase air cleaner
- Hydraulics protection package
- 4-Core Radiator

CHASSIS SYSTEM

- Massive One-Piece, unitized 3/16 thick steel frame
- Soft-ride tires

ENVIRONMENTAL FRIENDLY FEATURES

LOWER EMISSIONS

All gas and LP engines meet Tier 3 specifications, catalyst mufflers, diesel operated available, bio-diesel fuel can be used in Kubota engines.

SAFER WORK ENVIRONMENT

Orange machines are highly visible to others in the workplace, simple controls reduce operator error. Machine is equipped with a horn and an effective braking system. Some Safety Options available are: Overhead Guard, Backup Alarm, Safety Lights, and Fire Extinguisher.

SAFETY INFORMATION

IMPORTANT SAFETY INSTRUCTIONS

Operators must read and understand this manual before operating or maintaining this machine.

Do not operate this machine in flammable or explosive areas.

This machine is designed solely for removing dirt, dust and debris in an outdoor or indoor environment. PowerBoss does not recommend using this machine in any other capacity.

The following information indicate a potential hazard to the operator and equipment. Read this manual carefully and be aware when these conditions can exist. Take necessary steps to locate all safety devices on the machine and train the personnel operating the machine. Report any machine damage or faulty operation immediately. Do not use machine if it is not in proper operating condition.

FOR SAFETY DURING OPERATION

Keep hands and feet clear of moving parts while machine is in operation.

Make sure all safety devices are in place and operate properly. All covers, doors and latches must be in place, closed and fastened before use.

During operation, attention should be paid to other persons in the work area and especially if small children are present.

Components can cause an explosion when operated near explosive materials or vapor. Do not operate this machine near flammable materials such as solvents, thinners, fuels, grain dust, etc.

Store or park this machine on a level surface only. To prevent unauthorized use, machine should be stored or parked with the parking brake set and the key removed.

This machine is designed for level operation only. Do not operate on ramps or inclines greater than 14 degrees (24.9% grade).

This machine is not suitable for picking up hazardous dusts.

Use caution when moving this machine into areas that are below freezing temperatures.

SAFETY INFORMATION

SAFETY WHEN SERVICING OR MAINTAINING THE MACHINE

Stop on level surface, set parking brake and turn off machine.

Disconnect the power to the machine when servicing.

Avoid moving parts. Do not wear loose jackets, shirts, or sleeves when working on machine.

Avoid contact with battery acid. Battery acid can cause burns. When working on or around batteries, wear protective clothing and safety glasses. Remove metal jewelry. Do not lay tools or metal objects on top of battery.

Authorized personnel must perform repairs and maintenance. Use PowerBoss supplied replacement parts.

SAFETY SYMBOLS

Five symbols are used throughout this manual to emphasize various levels of safety information. These symbols and the meaning of each are listed below.

DANGER

To warn of immediate hazards which will result in severe personal injury or death

WARNING

To warn of hazards or unsafe practices which could result in severe personal injury or death.

CAUTION

To warn of hazards or unsafe practices which could result in minor personal injury.

ATTENTION!

To warn of practices which could result in extensive equipment damage.

NOTE: To direct your attention to important equipment information or special instructions for preventing damage to equipment

Symbols at the top of the list are the strongest warnings. However, all symbols represent important information which should be observed to protect you and others from harm and injury, and to prevent damage to the equipment.

SAFETY INFORMATION

SAFETY DECALS

Decals directly attached to various parts of the unit are highly visible safety reminders which should be read and observed. Make sure the decals are replaced if they become illegible or damaged.

Located in the operator compartment:
Part Number 3301854



Located on the shroud of the radiator:
Part Number 3301733



SAFETY INFORMATION

Located on the engine mount:
Part Number 3301730



Located on the side:
Part number 3342978



Located in the operator compartment:
Part number 3342264



Located behind the main broom doors:
Part number 715952

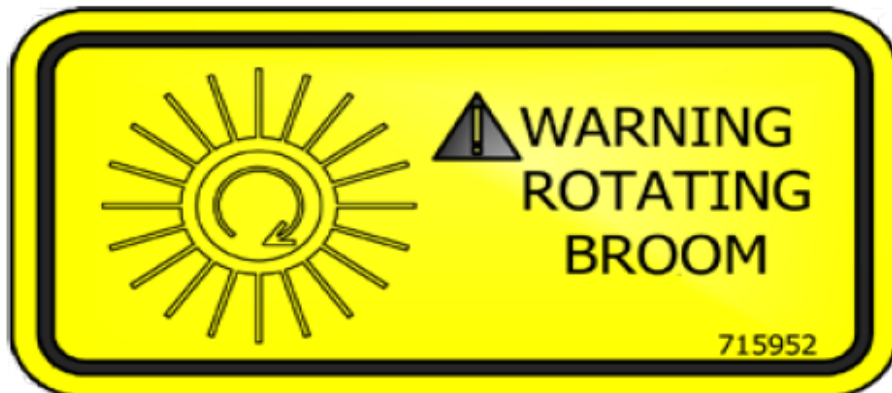

BASIC POWERBOSS® SAFETY

PowerBoss® scrubbers should never be operated unless:

1. The operator is trained and authorized to operate the equipment and,
2. The equipment is functioning correctly.
Malfunctioning equipment should be removed from service.

DANGER

Keep cigarettes, matches and all other flame sources away from the machine. Gasoline, LP Gas, and diesel fuels are highly flammable. Lead acid batteries are equally dangerous due to the highly explosive hydrogen gas they emit.

WARNING

Do not operate an LPG powered scrubber when any component in the fuel system is malfunctioning or leaking.

WARNING

Before starting the engine, make sure that:

- * You have read and understood this User Manual
- * You are securely seated in the operator's seat.
- * The parking brake is engaged.
- * The directional control pedal is in neutral.
- * The throttle is in idle.
- * Hydraulic controls are in the **OFF** position.

WARNING

During operation:

- * Keep your hands and body clear of moving parts, especially when the bumper is partially or fully raised.
- * Make sure others in the area stay clear of the machine, equipment, and moving parts.

⚠ WARNING

When leaving the scrubber unattended:

- * Place the controls in the **OFF** position.
- * Set the parking brake.
- * Shut off the engine.
- * Remove the key.

⚠ WARNING

When servicing or repairing the fuel system:

- * Work in a properly ventilated area, do not smoke or allow an open flame near the fuel system.
- * Never bypass safety components unless you are testing them.
- * Never bypass the fuel filter lock, except when testing them (and always reconnect them after testing).
- * Wear gloves to disconnect the tank coupling.

⚠ WARNING

During cleaning and maintenance:

- * Always stop the engine and set the parking brake before servicing.
- * Never use detergents or cleansers that are flammable or combustible.
- * Never inflate a pneumatic tire without using a safety cage.
- * Do not attempt any impeller adjustment unless you have shut off the engine. Never place your hands near the intake hoses or inlet when the engine is running.
- * Always engage the bumper safety arm before servicing the hopper. Do not rely on the gas struts to keep the bumper raised.
- * Never test for hydraulic hose leaks using your hand or any other part of your body. High pressure leaks can be very dangerous and should only be checked using a piece of paper.

SAFETY INFORMATION

⚠ WARNING

Replace any defective safety components before operating the scrubber.

⚠ CAUTION

Do not drive with the bumper in the raised position. Driving with the bumper raised increases the risk of damaging the bumper and other hazards.

⚠ CAUTION

Travel slowly on grades.

⚠ CAUTION

Place a block or chock behind the wheels when parking on inclines.

⚠ CAUTION

Use special care when traveling on wet surfaces.

⚠ CAUTION

Observe all proper procedures for operation and maintenance of the unit, as outlined in this manual.

⚠ CAUTION

Remain alert at all times to people and equipment in and around your area of operation.

ATTENTION!

Never push or tow this machine faster than 1 mph.

ATTENTION!

Engage tow valve before towing or pushing.

TRANSPORTING THE MACHINE

USING A TRAILER OR TRANSPORT VEHICLE

1. Position the machine on the transport vehicle or trailer and apply the parking brake.
2. Tie the machine down using the tie down bars on both sides of the front corners and behind both rear wheels.

Note: Attach the tie downs to the tie down bars only.

PUSHING OR TOWING THE MACHINE

Before towing or pushing the machine, turn the bypass valve located on the top of the propulsion pump 90 degrees as shown. See Fig. 2.

⚠ CAUTION

The tow control valve must be turned 90 degrees from the operating position.
Not turning the tow control valve will cause damage to the pump.

ATTENTION!

Do not tow or push the machine a distance of more than .5 miles (.80 kilometers) or faster than one mile per hour (1.61 km). Exceeding these restrictions may cause damage to the hydraulic system. If towing will exceed the above restrictions, the rear wheel must be raised or supported by a dolly.

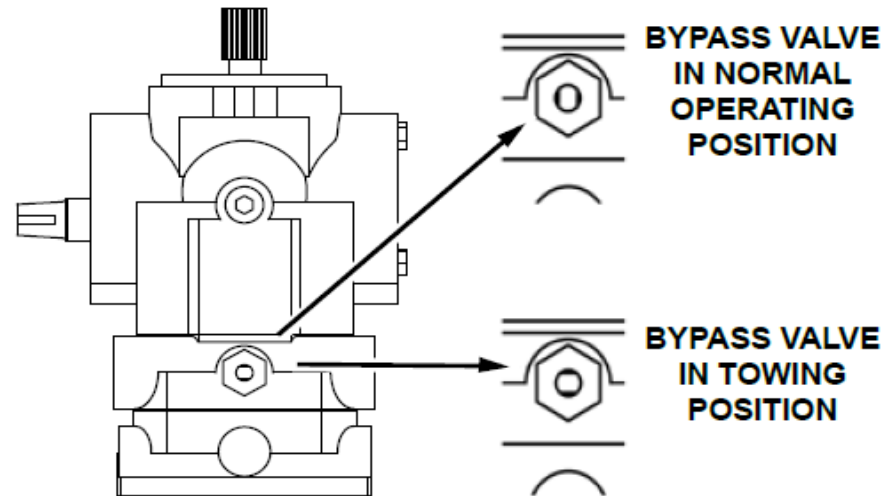

Fig. 2: Bypass Valve locations

PREVENTATIVE MAINTENANCE

Introduction

Regular maintenance on your sweeper results in better cleaning, faster cleaning and a prolonged service life for the equipment and components. This section contains the following information to help you give your sweeper the maintenance attention it requires:

- A Scheduled Maintenance Chart
- Preventative Maintenance Instructions for Required Scheduled Maintenance Tasks

Because it is extremely important to your safety, you will see the following **WARNING** repeated throughout this section:

 **WARNING**

Never attempt to perform any service on the equipment or components until the engine is OFF, the parking brake is LOCKED, and the wheels are CHOCKED.

SCHEDULED MAINTENANCE CHART

FREQUENCY (IN HOURS)

DAILY	50	100	200	500
-------	----	-----	-----	-----

SERVICE

(BY MAINTENANCE AREA)

ENGINE

		X		
--	--	---	--	--

Pressure wash engine

NOTE: For additional maintenance requirements, refer to the engine manual.

AIR INTAKE SYSTEM

X				
---	--	--	--	--

Empty rubber dust cup of air filter element.

X				
---	--	--	--	--

Check air filter indicator

	X			
--	---	--	--	--

Clean air filter. *NOTE: Clean more often in dusty conditions.*

			X	
--	--	--	---	--

Replace air filter.

ELECTRICAL SYSTEM

			X	
--	--	--	---	--

Clean battery top.

COOLANT SYSTEM

X				
---	--	--	--	--

Check coolant level and fill as needed.

	X			
--	---	--	--	--

Inspect radiator fins and clean as needed.

		X		
--	--	---	--	--

Blow out radiator fins.

SCHEDULED MAINTENANCE CHART

FREQUENCY (IN HOURS)

DAILY	50	100	200	500
-------	----	-----	-----	-----

SERVICE (BY MAINTENANCE AREA)

LUBRICATION POINTS

				X	Lubricate steering cylinder rod end.
				X	Lubricate steering fork.
			X		Lubricate scrub head lift arm bearings
				X	Hood Latches & Hinges Lubricate type - oil

IMPELLER

X					Check for hydraulic fluid leaks from hoses and motor.
---	--	--	--	--	---

HYDRAULIC SYSTEM

X					Check hydraulic reservoir gauge and fill as needed.
				X	Replace breather cap filter element.
				X ¹	Replace hydraulic fluid and filter
X					Check function of directional control pedal (hydrostatic transmission) and adjust as needed.
				X	Clean hydraulic fluid strainer in reservoir.
	X				Inspect hydraulic oil cooler fins and clean as needed (if so equipped).
		X			Blow out hydraulic oil cooler fins with compressed air (if so equipped).

Notes:1. Replace as indicated by hydraulic filter gauge.

SCHEDULED MAINTENANCE CHART					
FREQUENCY (IN HOURS)					SERVICE (BY MAINTENANCE AREA)
DAILY	50	100	200	500	
SWEEPING COMPONENTS					
X					Inspect brushes for wear and remove strings and debris from bristles and drive assembly.
	X				Scrub head front & rear wear and damage, adjust or replace as needed.
				X	Perform brush taper pattern test and adjust if needed.
					Replace main scrub brushes as needed: Main Brushes needs to be replace if bristles are 1/2" in length or less.
STEERING					
	X				Check for leaks.
PARKING BRAKE					
			X		Check for proper functioning and adjust as needed.
WHEELS AND TIRES					
X					Visually inspect for wear and damage. Repair or replace as needed.
	X				Check and tighten lug nuts. (torque to 100 ft.-lbs)
MISCELLANEOUS					
				X	Inspect latches and hinges. Tighten and lubricate as needed.
			X		Check anti-static strap on rear wall of broom chamber for damage or excessive wear. Replace as needed.

PREVENTATIVE MAINTENANCE INSTRUCTIONS

ENGINE

Maintenance requirements and service instructions for your Scrubber/Sweeper engine are outlined in the following parts of this Maintenance Section:

- Air Intake System
- Electrical System
- Fuel System
- Coolant System
- Lubrication System

All basic maintenance tasks are listed with their recommended frequencies on the Planned Maintenance Chart in this manual. Important additional engine maintenance requirements and instructions are explained in the Engine Supplemental Catalog which comes with your machine.

WARNING

Never attempt to perform any service on the equipment or components until the engine is **OFF, the parking brake is **LOCKED**, and the wheels are **CHOCKED**.**

AIR INTAKE SYSTEM

Check Air Filter Service Indicator

The air filter service indicator shows when to change the air filter element. Check the indicator on a daily basis. The red indicator gradually becomes visible as the air filter elements load with dirt. It is not necessary to change the air filter elements until the red indicator reaches the top of the service indicator and locks into position.

1. Lift engine cover
2. Inspect air filter service indicator.

Note: The indicator may return to the nonviable position when the engine is shut off. To check, reset indicator and turn on the engine, if it locks in visible position again clean or change element.

Air Filter Element Removal

1. Turn off the engine and set the parking brake.
2. Lift the engine top cover and side door.
3. Locate the air filter and loosen the retaining clamp.
4. Remove the dust cup.
5. Pull the rubber plug out of the dust cup and empty the contents.
6. Pull the air filter elements out of its housing.

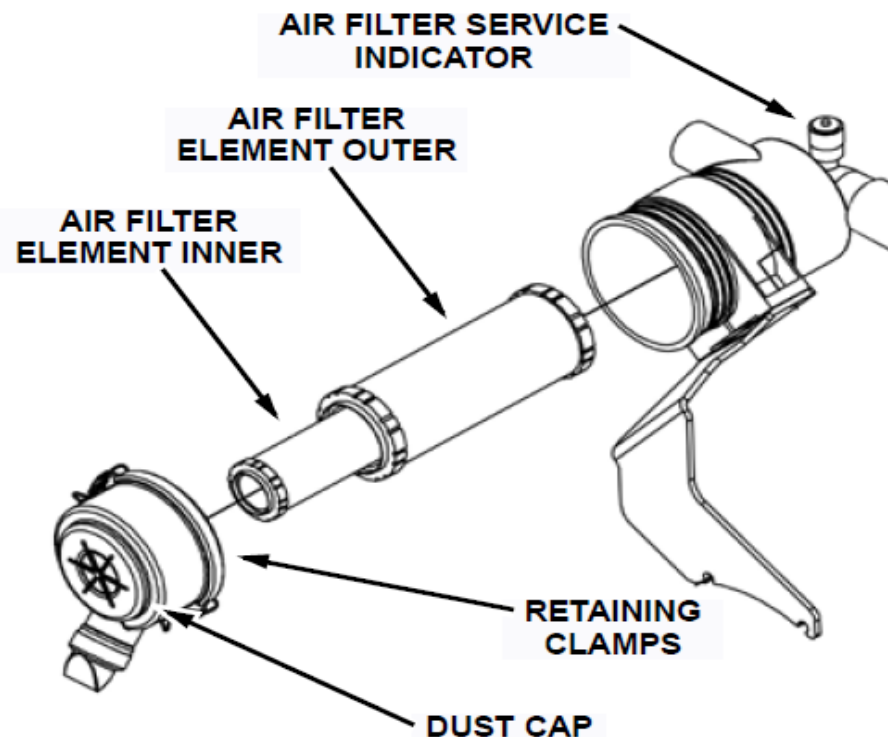

Fig. 1: Air Intake System

Air Filter Cleaning

1. Once you have removed the air filter elements, empty the dust cup and clean the interior of the air filter housing.
2. Use an air hose to blow out the air filter elements. Air pressure should be 100 psi or less.

Air Filter Inspection

1. After you clean the air filter elements, check the elements for holes by passing a light bulb inside it.

Air Filter Installation

1. Wipe out the air cleaner housing with a damp cloth. Be sure all dirt is removed.
2. Install the cleaned replacement filter elements so that the fins are at the far end of the housing. Be careful not to damage the fins.
3. Replace the rubber plug in the dust cup.
4. Replace dust cup, being sure embossed word "top" on cup is positioned correctly (up).
5. Tighten the retaining clips.
6. Check the condition of intake hoses and clamps. Close engine top cover and side door.

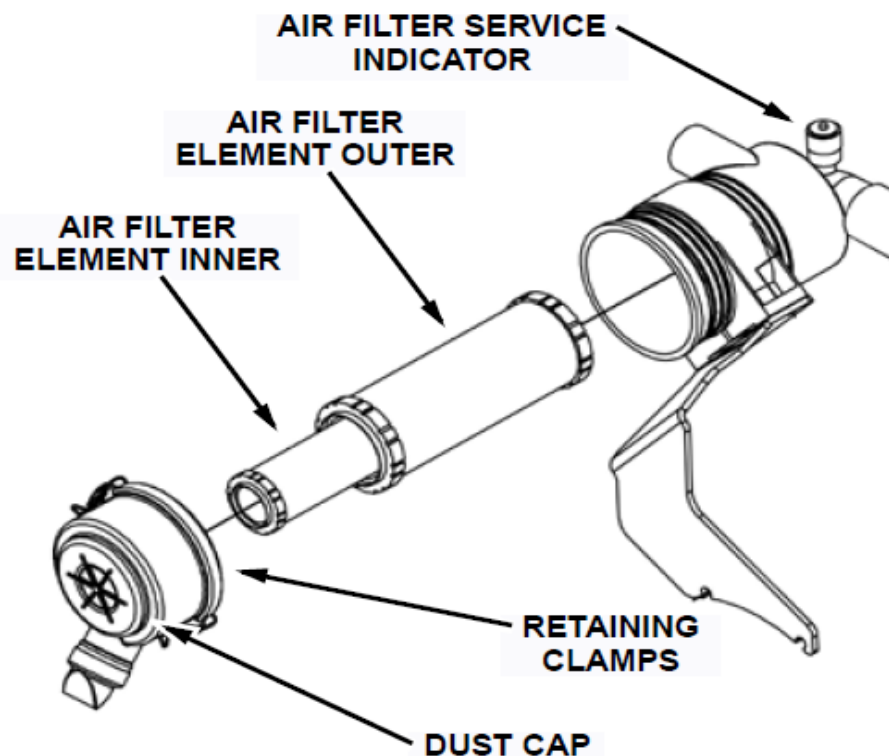



Fig. 1: Air Intake System

ELECTRICAL SYSTEM

Battery Cleaning

1. Combine baking soda and water in a strong solution.
2. Brush the solution over the battery top, including terminals and cable clamps. Make sure the solution does not enter the battery.
3. Using a wire brush, clean the terminal posts and cable clamps.
4. Apply a thin coating of petroleum jelly to the terminals and cable clamps.

Battery Replacement

 **CAUTION**

Remove the negative battery cable before you remove the positive battery cable. This is done to prevent accidental electrical shorting which can result in personal injury.

1. Disconnect the negative (-) cable and then the positive (+) cable.
2. Remove the battery.
3. Install the new battery.
4. Connect the positive (+) battery cable first, then the negative (-) cable.

LUBRICATION POINTS

Steering Fork Bearings

The steering fork bearings are located above the front wheel.

Rear Wheel Bearings

Repack the rear wheel bearings every 400 hours of operation using Lubriplate EMB grease and replace damaged seals.

Squeegee Caster Bearings

Lubricate the squeegee caster bearings every 100 hours using Lubriplate EMB grease.

Scrub Head Lift Arm Bearings

Lubricate the hopper lift bearings every 500 hours with light oil.

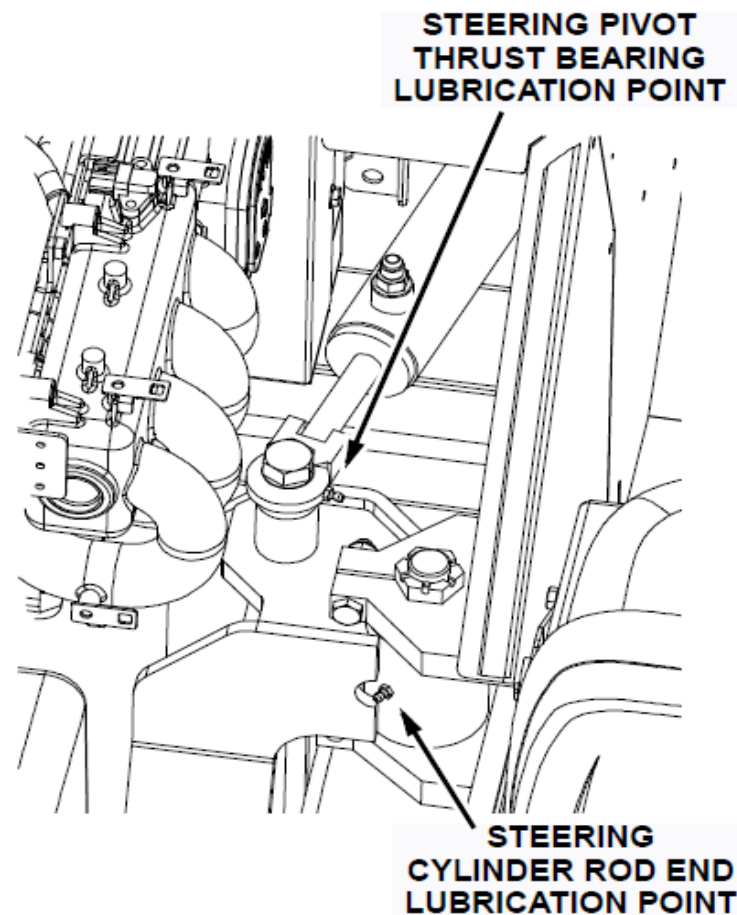

Fig. 1: Lubrication Points

LATCHES & HINGES

Lubricate the cover hinges every 200 hours of operation with light machine oil. Lubricate the following:

- Front cover, hinges and latches
- Side doors, hinges and latches
- Top cover, hinges and latches
- Scrub head doors

The scrub head lift arm bearings are located on both sides of the machine just above the scrub head. These bearings can be best accessed when the scrub head is in the lowered position.

Lubricate the steering fork bearings every 100 hours using Lubriplate EMB grease.

STATIC STRAP

A static strap prevents the buildup of static electricity in the machine. The static strap is attached to the frame in front of the left scrub door. Replace the static strap if it is damaged or no longer touches the floor.

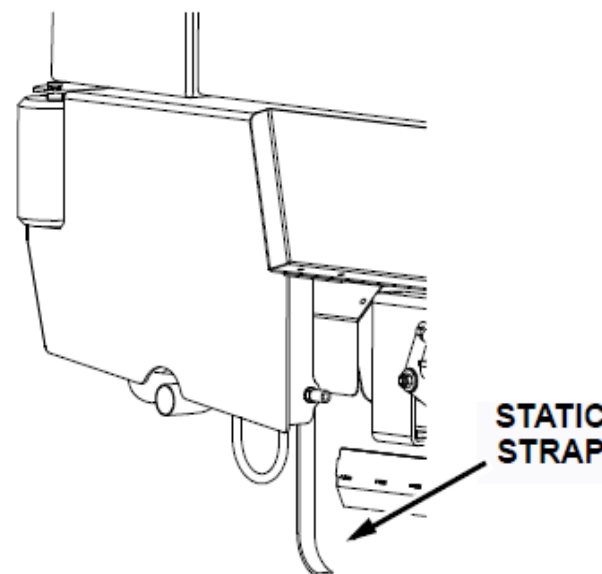

Fig. 1: Static Strap

HYDRAULIC SYSTEM

Hydraulic Fluid Reservoir

The hydraulic fluid reservoir is located behind the right side door under the operator seat. (See Fig. 1)

Note: The reservoir fill cap has a built-in breather and dip stick. Replace the cap every 100 hours of operation.

Note: The hydraulic oil filter contains a replaceable element. Replace the filter element every 100 hours of operation.

The reservoir has a sight gauge to quickly view if there is a sufficient amount hydraulic oil in the reservoir tank to run the machine. Check daily and add hydraulic oil as needed.

When the machine is cool unscrew the fill cap and check the fluid level on the attached dip stick. The fluid level should be between the high and low markers. The cap should be screwed down hand tight and unscrewed to get a proper oil level reading. Add or remove hydraulic fluid as needed.

CAUTION

**DO NOT OVERFILL HYDRAULIC RESEVOIR TANK!
DO NOT USE TRANSMISSION FLUID!**

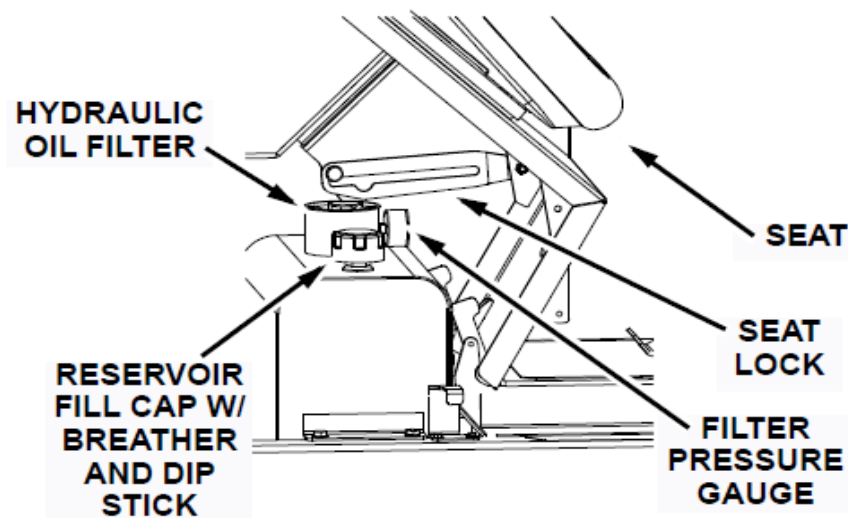

Fig. 2: Hydraulic Fluid Reservoir location



Fig. 3: Hydraulic Fluid Gauges

⚠ CAUTION

PowerBoss, Inc. **RECOMMENDS USING:**

Megaflow® AW HVI Hydraulic Oil 32 or **EQUIVALENT!**

Hydraulic Fluid Viscosity Specifications for (Megaflow® AW HVI Hydraulic Oil 32)

cSt @ 40° C (104° F): 32.0

cSt @ 100° C (212° F): 6.0

Changing the Hydraulic Fluid

1. Turn off the engine and engage the parking brake.
2. Place a drain pan under the reservoir tank.
3. Remove the drain plug, unscrew with 5/16" hex head wrench, located on the bottom of the reservoir and allow the fluid to drain.
4. Discard the fluid in an approved manner, then replace and retighten the drain plug.
5. Remove the fill cap located on top of the reservoir and fill the reservoir with the recommended hydraulic fluid: (Megaflow® AW HVI Hydraulic Oil 32 or equivalent).

Note: A minimum of 7 and up to 8 gallons of hydraulic oil is needed to fill the empty reservoir tank to the correct amount. The maximum volume capacity of the hydraulic reservoir tank is 9.9 gallons. Do not fill to this maximum capacity!

6. Visually see if the hydraulic oil level is at or above the sight gauge. Confirm the hydraulic oil level is within the high and low markers on the dip stick. Add or remove hydraulic fluid as needed. (Reference approximate fill line)
7. Verify the fill cap is hand tight to prevent leakage.
8. Start the machine, shut it off, then check for leakage.

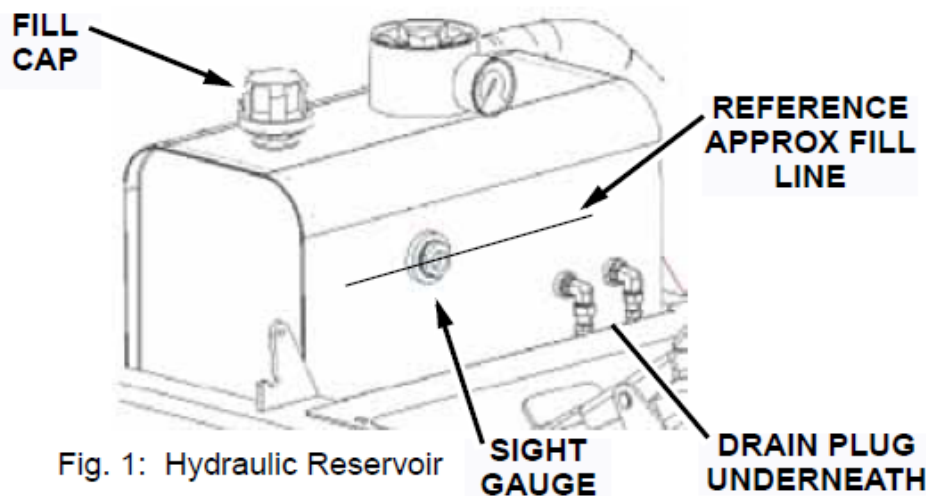

Fig. 1: Hydraulic Reservoir

Hydraulic Fluid Filter

The reservoir tank has a pressure gauge to monitor hydraulic fluid pressure and to indicate when the hydraulic fluid filter needs to be replaced.

The pressure gauge needle indicates green, yellow, and red pressure zones. When the needle reaches the red pressure zone, the filter needs to be replaced.

Note: The pressure gauge should be observed when engine is on. This gauge can be viewed from the sight hole below the operator seat.

Changing The Hydraulic Fluid Filter

1. Turn off the engine and engage the parking brake.
2. Access the filter by tilting the operator seat forward and engaging the seat lock. The fluid filter will be visible on top of the reservoir tank.
3. Unscrew the filter with an 15/16 wrench, and remove the fluid filter from the top of the reservoir.
4. Screw the new filter in position and tighten with an 15/16 wrench.

Note: Do not over tighten.

5. Start the machine, shut it off, then check for leakage.

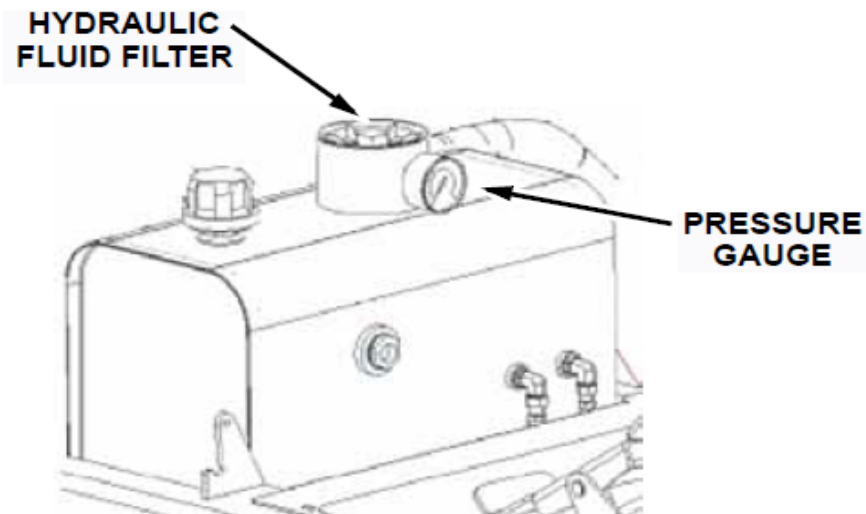

Fig. 2: Hydraulic Filter & Pressure Gauge

Maintaining Hydraulic Oil Cooler Efficiency

Your machine is equipped with a hydraulic oil cooler, it is integrated with the radiator and utilizes exhausted radiator air from the engine fan to cool the hydraulic fluid.

To maintain its efficiency, periodically blow out the radiator and oil cooler fins with compressed air 100 p.s.i. is maximum.

Adjusting the Propulsion Pump Neutral Setting

If the machine does not remain in neutral when the foot pedal is released the following adjustment is necessary.

⚠ WARNING

Before starting the engine raise the front of the machine with a suitable floor jack so that the drive wheel is lifted off the floor. This will insure that the machine will not move forward or backward while the neutral setting is being adjusted!

1. Raise the front of the machine with a suitable floor jack so that drive wheel is off the floor.
2. Slightly loosen the two bolts holding the Hydroback adjuster plate to the Hydroback mount so that the plates remain in contact but the adjuster plate can move.
3. Start the engine and position the throttle switch to the high speed position.
4. Push the directional control pedal in the forward direction and release, then push the pedal into reverse and release.
5. Note the direction that the drive wheel is rotating when the directional control pedal released.

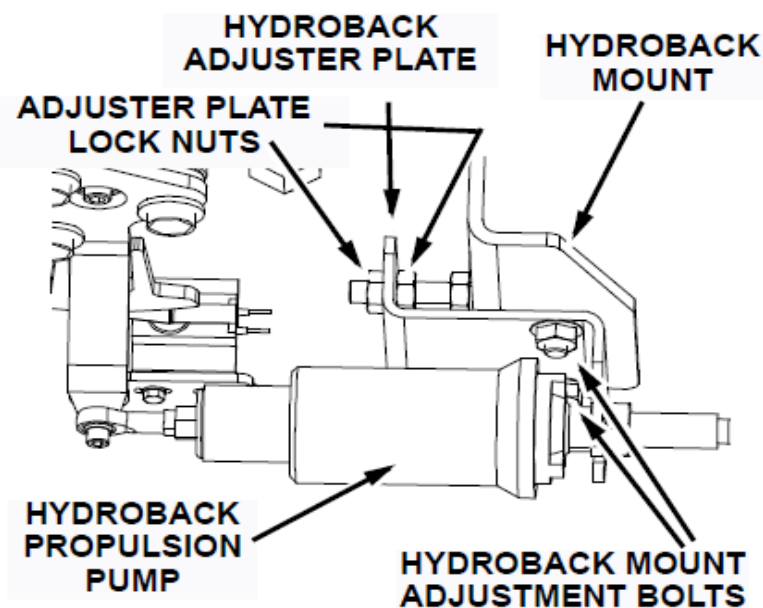

Fig. 1: Hydroback Propulsion Pump

6. **If the drive wheel rotates in the forward direction:** Slowly turn the lock nuts located on either side of the Hydroback adjuster plate so that the adjuster plate is moved to the right.
7. **If the drive wheel rotates in the reverse direction:** Slowly turn the lock nuts located on either side of the Hydroback adjuster plate so that the adjuster plate is moved to the left.

8. When the drive wheel comes to a complete stop tighten the two lock nuts.
9. Tighten the two fasteners holding the Hydroback adjuster plate to the Hydroback mount.
10. Repeat step 4 above to verify that the neutral position is correctly adjusted. If not repeat steps 1 through 9 above.
11. Turn off the engine and lower the machine to the floor.

Note: The Neutral Switch must be re-adjusted after adjusting the propulsion pump. See the Neutral Sensing Switch section on page 36

Drive Motor

After the first 50 hours of operation torque the motor shaft nut to 475 ft-lb (644 Nm) dry; 375 ft-lb (508 Nm) lubricated. Repeat this again after each 800 hours of operation.

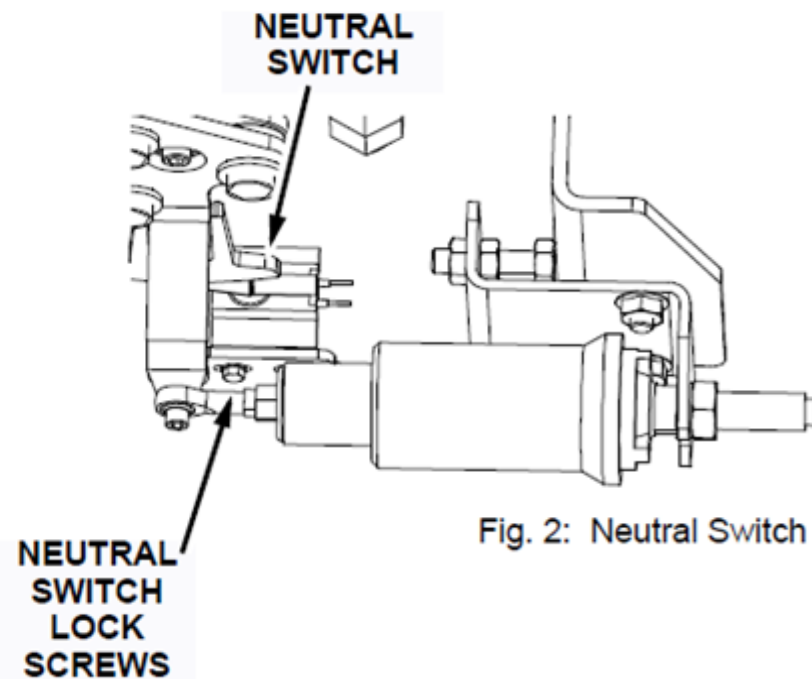

Fig. 2: Neutral Switch

Checking the Scrub Brush Pattern

For the best results perform the scrub brush pattern tests on a smooth even floor.

Note: Chalk or chalk powder applied to the floor will help to show the brush pattern. If chalk is not available allow the brushes to turn on the floor for 1 or 2 minutes. A polished brush pattern will be visible on the floor.

1. Raise the scrub deck.
2. Position the scrub deck over the chalked area.
3. Set the parking brake.

For Safety: Before leaving machine, turn off the machine, set the parking brake, and remove the key.

4. Lower the scrub head for 10-15 seconds. Do not allow the machine to move forward or backward.
5. Raise the scrub deck.
6. Release the parking brake and drive the machine away from the chalked area.

7. Check the width and shape of the brush patterns on the floor. If the long edges of the two brush patterns are parallel then a brush pattern adjustment is not required.

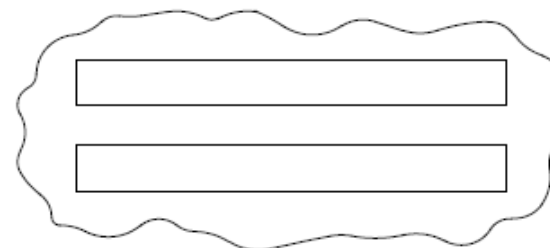

Fig. 1: Brush Pattern Correct

If only one of the scrub brush patterns is tapered then only that brush pattern must be adjusted. If both of the brush patterns are tapered then both brush patterns must be adjusted.

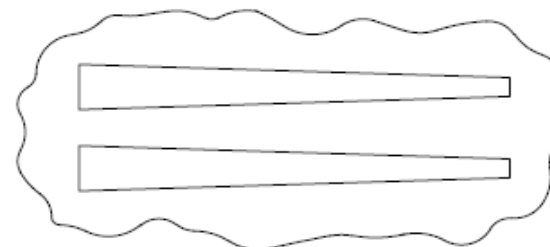

Fig. 2: Brush Pattern Incorrect

Adjusting the Scrub Brush Pattern (Taper)

The front scrub brush pattern adjustment is located behind the right side scrub brush door.

The rear scrub brush pattern adjustment is located behind the left side scrub brush door.

1. Raise the scrub brush side door.
2. Release the retaining latch at the rear of the side squeegee mount and swing the side squeegee mount open.
3. Loosen the four pattern adjustment nuts located on either side of the scrub brush idler plate.
4. Raise or lower the scrub brush idler plate as necessary to correct the tapered brush pattern. Raising the idler plate will decrease the brush pattern width on that side of the scrub deck.

Note: Lowering the idler plate will increase the brush pattern width on that side of the scrub deck.

5. Tighten the four pattern adjustment nuts.
6. Close and latch the side squeegee mount. The side squeegee mount holds the brush idler plate in place.
7. Check the scrub brush pattern again and readjust if necessary.

The brush patterns should also be the same width. If one is wider than the other then the scrub brush pattern width must be adjusted.

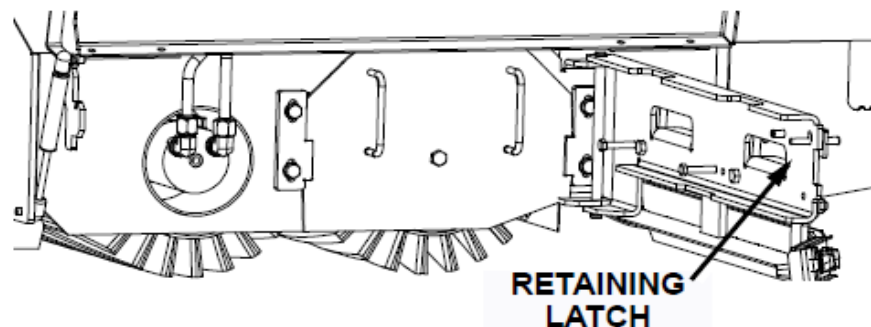

Fig. 1: Retaining Latch location

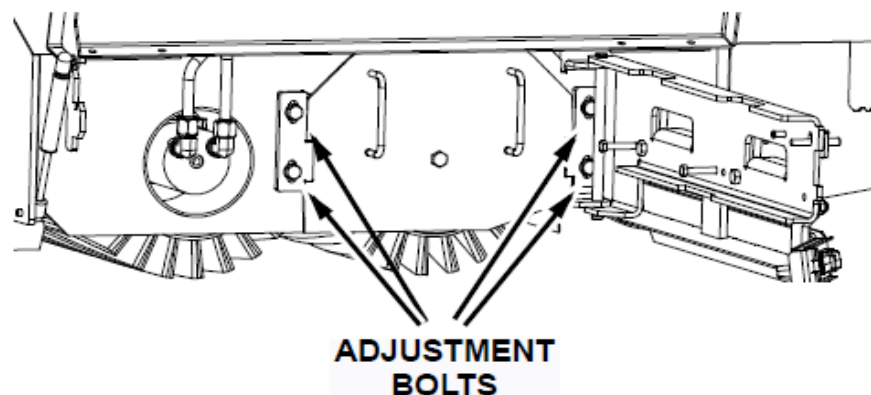

Fig. 2: Adjustment Bolts, location

Adjusting the Scrub Brush Pattern (Equal width)

The width of the two scrub brush patterns should be equal. If they are not equal the level of the scrub deck must be adjusted front-to-back. (See Fig. 3)

1. Open the two side doors and raise the seat mount.
2. Lengthen or shorten the leveling rods located on each side of the machine above the scrub deck. Lengthening the rods will increase the front scrub brush pattern width. (See Fig. 4)
3. Adjust the leveling rods in equal amounts.
4. Check the scrub brush pattern again and readjust if necessary.

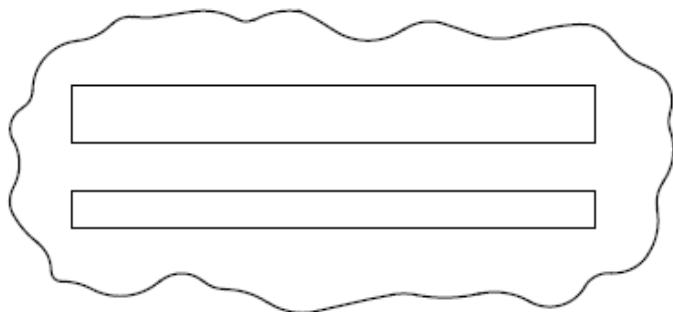

Fig. 3: Brush Pattern (width not equal)

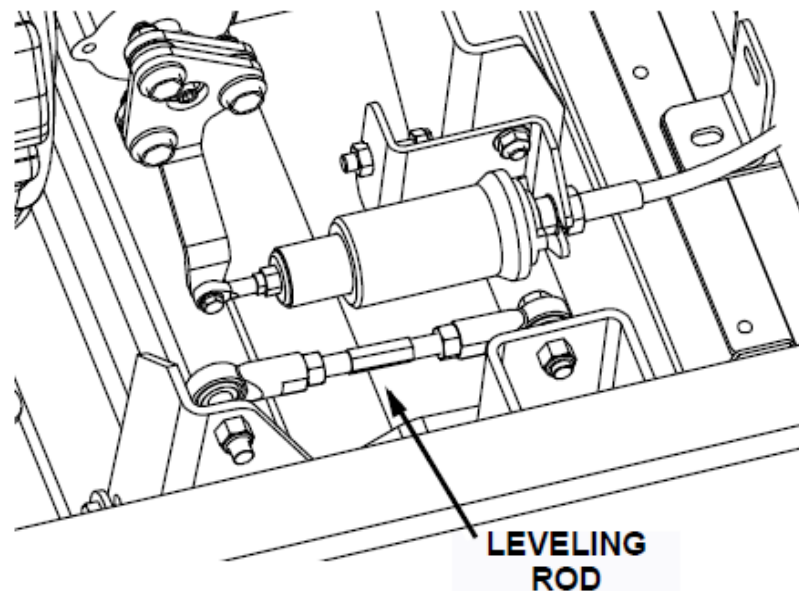

Fig. 4: Leveling Rod location

SQUEEGEES

The right and left side squeegees control water during turns and channel water toward the center of the machine and into the path of the rear squeegee.

The rear squeegee channels water to the center of the squeegee where it is removed by the vacuum fan.

The optional side scrub brush squeegee channels water to the inside of the right side squeegee.

Check the squeegee blades daily for wear or damage. Replace or rotate the squeegee blades if the edges are torn or worn half-way through the thickness of the blade.

The rear squeegee blades must be adjusted to be level and for correct deflection.

Checking the Rear Squeegee Blade Flare

Squeegee flare is the amount of curl in the squeegee blade as it drags on the floor while the machine is moving forward. Correct squeegee blade flare is necessary for optimum water pick up. The correct flare adjustment is achieved when the squeegee wipes the floor dry with the least amount of deflection. It is important that this check be performed on an even, level surface.

1. Lower the squeegee.
2. Drive the machine forward approximately 2 ft (0.6m).
3. Set the parking brake.
4. Examine the curl in the squeegee rubber to see that the flare is correct and that it is uniform around the entire back edge of the squeegee blade:

Adjusting the Rear Squeegee Blade Flare

Be sure that the squeegee assembly is adjusted to level before performing the flare adjustment. It is important that this adjustment be performed on an even, level surface.

Note: Raising the squeegee casters increases the squeegee flare, lowering the casters reduces the squeegee flare.

1. Lower the squeegee.
2. Press and hold the idle button located under the key switch.
3. While holding the idle button turn off the engine key switch Set the parking brake.
4. Lift the squeegee assembly up by hand and allow it to rest back down on the floor. The squeegee blade should be standing straight up on the floor with no flair.
5. Loosen the locking knobs on the squeegee casters.
6. Adjust the casters until they clear the floor by 1/4" (6.3mm). Use a 1/4" (6.3mm) thick spacer for this procedure.
7. Check the squeegee flare (See **Checking the Rear Squeegee Blade Flare**).
8. Test the squeegee for water pick up.
9. Make fine adjustments to the caster height for optimum water pick up on the floor surface to be cleaned.

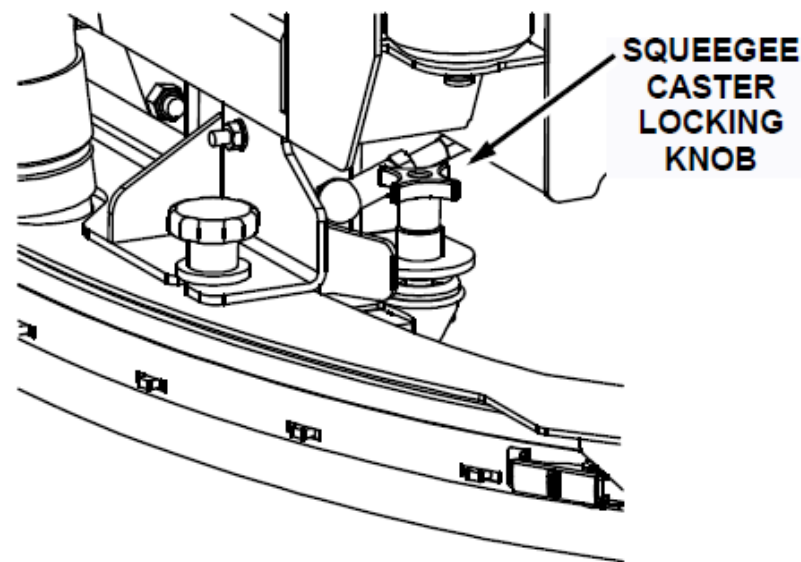

Fig. 1: Adjusting the Rear Squeegee Blade Flair

Leveling the Rear Squeegee

Leveling the squeegee assembly provides a uniform flare of the squeegee blade. It is important that this adjustment be performed on an even, level surface.

1. Lower the squeegee.
2. Drive the machine forward approximately 2 ft (0.6m).
3. Set the parking brake.
4. Examine the curl in the squeegee rubber around the entire back edge of the squeegee blade.

If the flare is not even across the rear squeegee blade proceed with the following:

5. Locate the two sets of adjustment nuts on the two squeegee adjustment rods.

Note: Raising the rear bumper and then lowering the squeegee will provide greater access to the adjusting nuts.

6. To lower the front of the squeegee turn the two adjustment nuts on each adjustment rod rearward (away from the front of the machine).

To lower the rear of the squeegee turn the two adjustment nuts on each adjustment rod forward (toward the front of the machine).

7. Lock the adjustment nuts.
8. If necessary proceed to **Adjusting the Rear Squeegee Blade Flare**.
9. Test the squeegee for water pick up.
10. Re-adjust to level the squeegee if necessary.

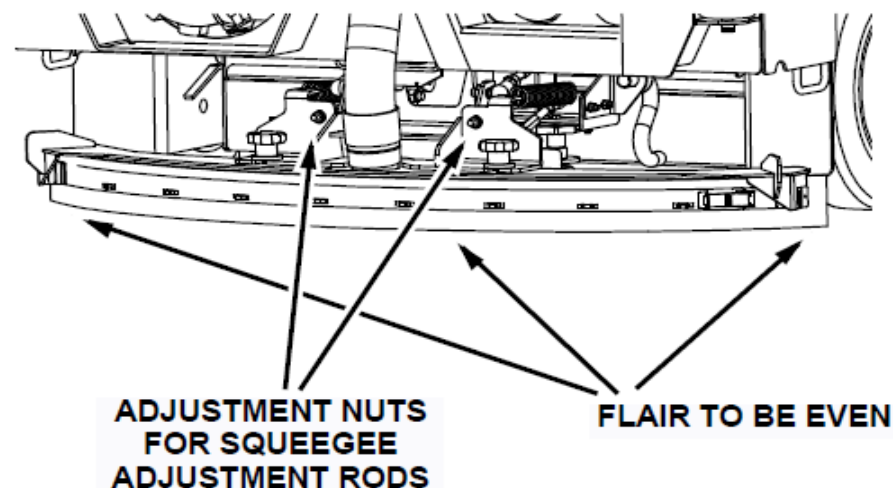

Fig. 2: Leveling the Rear Squeegee

BRAKES

Service Brakes

The service brakes are operated by a foot pedal and connecting cables. (See Fig. 1)

Check the service brake adjustment every 200 hours of operation.

Parking Brake

The parking brake is operated by a locking foot pedal that activates the service brakes. (See Fig. 1)

Check the service brake adjustment every 200 hours of operation.

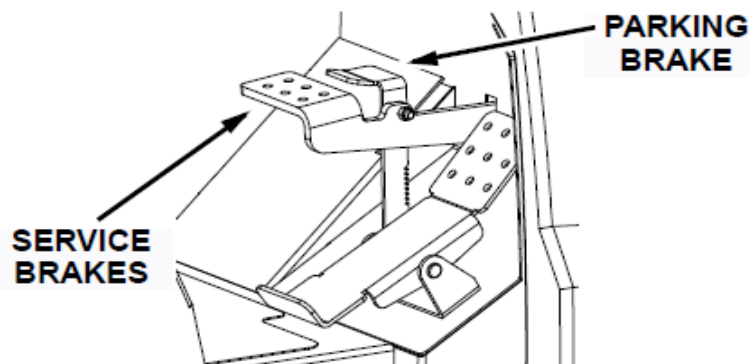

Fig. 1: Service and Parking Brakes

Adjusting the Brake System

Both the service and parking brake are adjusted during the following cable length adjustment.

The brake cable adjustment is located under the operator compartment floor behind the front cover. (See Fig. 1)

1. Loosen the locking nut on the adjustment hex bar.
2. Adjust the length of the cable by turning the adjustment hex bar.

Note: The cable should be adjusted so that there is little play in the brake pedal but not so tight to cause the brakes to drag when the brake pedal is released.

3. Test the brakes and re-adjust if necessary.
4. Tighten the locking nut.

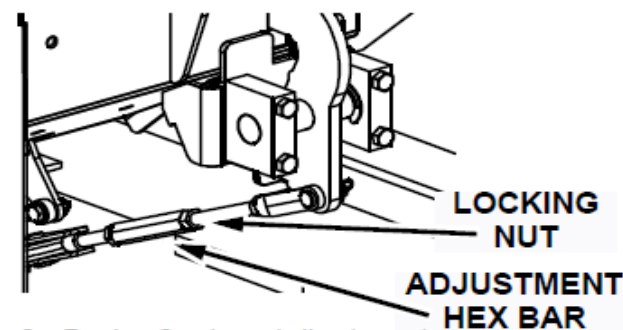

Fig. 2: Brake System Adjustment

TIRES

The front and rear tires are solid press-on tires.

Check the tires for damage every 100 hours of operation.

Changing Solid Tires

Note: The procedures that follow apply to SOLID TIRES ONLY!

Front Tires

1. Remove the tire from the vehicle by removing the 5 lug nuts.
2. Press the tire from the rim.
3. Press the new tire onto the rim.
4. Reinstall the tire on the machine.
5. Tighten the five wheel lug nuts to 90-110 ft lb (122-149 Nm).

Rear Tires

1. Remove the tire from the vehicle by removing the center axle nut.
2. Pull the rear tire straight off of the axle.

3. Remove the inner and outer bearings. Note which is the inner bearing and which is the outer bearing so that they are reinstalled in the same location.
4. Press the tire from the rim.
5. Press the new tire onto the rim.
6. Clean the inner and outer bearing races and bores.
7. Clean the bearings. Inspect the bearings and races for wear, replace if necessary.
8. Grease the bearings with Lubriplate EMB or equivalent.
9. Install the bearings in the wheel. Insure that the bearing seals are seated correctly and being careful not to get any grease on the brake surface or brake pads.
10. Reinstall the tire on the machine by holding the wheel parallel to the side of the vehicle and firmly push it onto the axle.
11. Torque the wheel nut to 100 in-lb (11.3 Nm)
12. Align the hole in the axle with the closest slot on the nut and install the cotter pin.
13. Install the hub cap.

SENSING SWITCHES

Adjusting the Neutral Sensing Switch

The Neutral Sensing Switch shuts off and raises the scrub brushes and turns off the solution flow whenever the vehicle is not in motion. When vehicle motion resumes the scrub brushes automatically turn on and lower and the solution flow is turned on.

The Neutral Sensing Switch is a normally open roller switch located below and inboard of the pump centering unit (Hydroback unit).

The switch is activated by a cam attached to the pump centering arm.

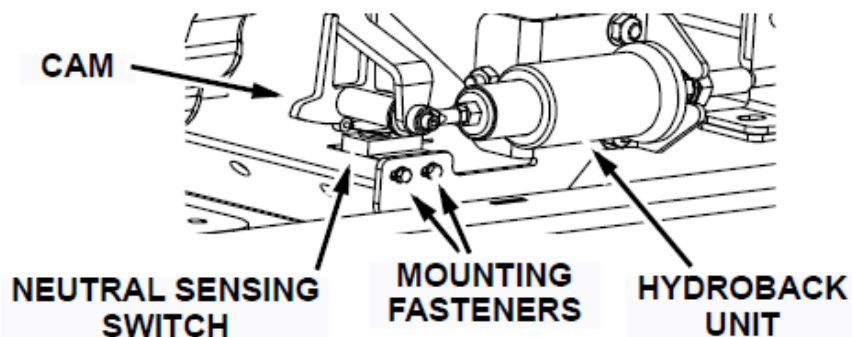

Fig. 1: Adjusting the Neutral Sensing Switch

Neutral Sensing Switch Adjustment:

Note: Hydrostatic transmission neutral must be set before performing this adjustment.

The cable should be adjusted so that there is little play in the brake pedal but not so tight to cause the brakes to drag when the brake pedal is released. (See Fig. 1 & 2)

1. Slightly loosen the neutral switch mounting fasteners so that the switch can be repositioned by hand.

The adjustment can be monitored by listening to the sound of the switch as it opens and closes.

2. Begin the adjustment by moving the switch body so that the roller fits up into the half-round cut out in the cam. This is the neutral position and the switch should be open.

Insure that the switch body is kept level during adjustment.

3. Adjust the switch body so that that a very small amount of pump arm motion will force the roller down and close the switch.

This adjustment should be made while pushing the pump arm slightly forward by hand (towards the front of the vehicle) and then releasing the arm while listening for the switch to close and open.

It is important that the switch reacts quickly otherwise it will be necessary to drive the vehicle at too high a speed before the brushes become activated.

4. Insure that the switch also closes and opens when the pump arm is pushed slightly to the rear and released.
5. Tighten the switch fasteners and retest.

Adjusting the Nautilus Reverse Sensing Switch

To prevent squeegee damage a reverse sensing switch causes the rear squeegee to raise whenever the vehicle moves in reverse. When the vehicle is stopped or resumes forward motion the rear squeegee automatically lowers back to the floor.

The neutral sensing switch is a whisker-type switch located below the directional control pedal. The switch is activated by the directional control pedal arm. (See Fig. 3)

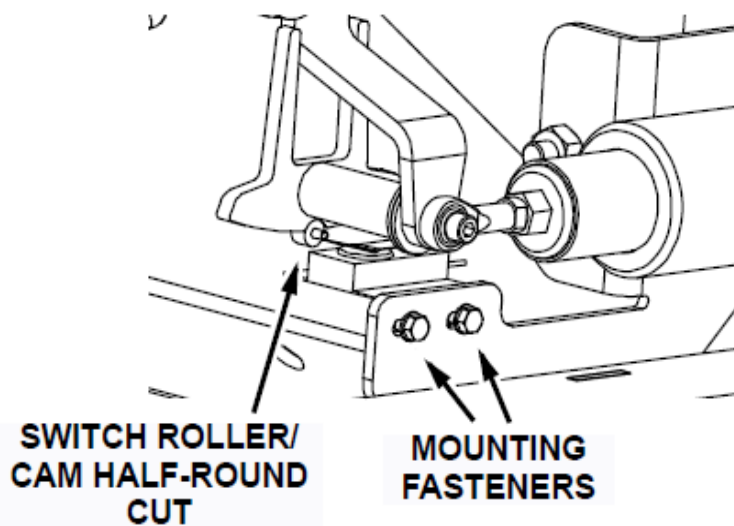

Fig. 2: Roller and Cam Position

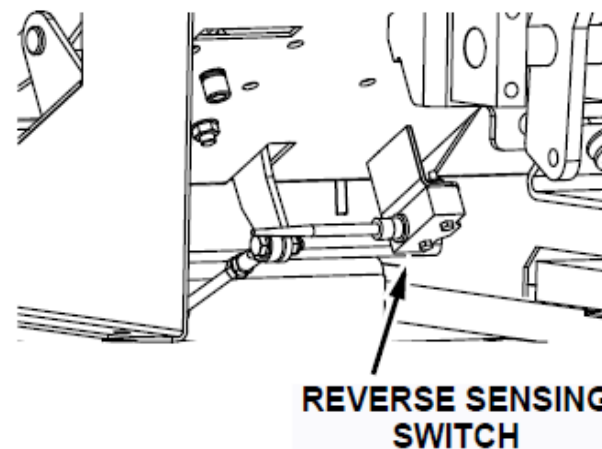

Fig. 3: Reverse Sensing Switch location

Nautilus Reverse Sensing Switch Adjustment:

Note: The heel end of the directional control pedal, when in neutral, must be set to 3/4 inch above the operator compartment floor before performing this adjustment.

1. Slightly loosen the neutral switch mounting fasteners so that the switch can be repositioned by hand. (See Fig. 1)

The adjustment can be monitored by listening to the sound of the switch as it opens and closes.

2. Adjust the switch body so that the switch is already activated when the directional control pedal is in neutral and stays activated when the pedal is pushed in the forward direction. The switch should close immediately upon moving the pedal into the reverse direction. It is important that only a very small amount of reverse pedal movement closes the switch.

It is important that the switch reacts quickly in reverse otherwise the vehicle will have to travel too fast in reverse before the rear squeegee is raised or may not raise at all when moving in reverse at low speed.

3. Insure that the switch activates correctly when the directional control pedal is pushed slightly forward and released and when pushed slightly in reverse and released.
4. Tighten the switch fasteners and retest.

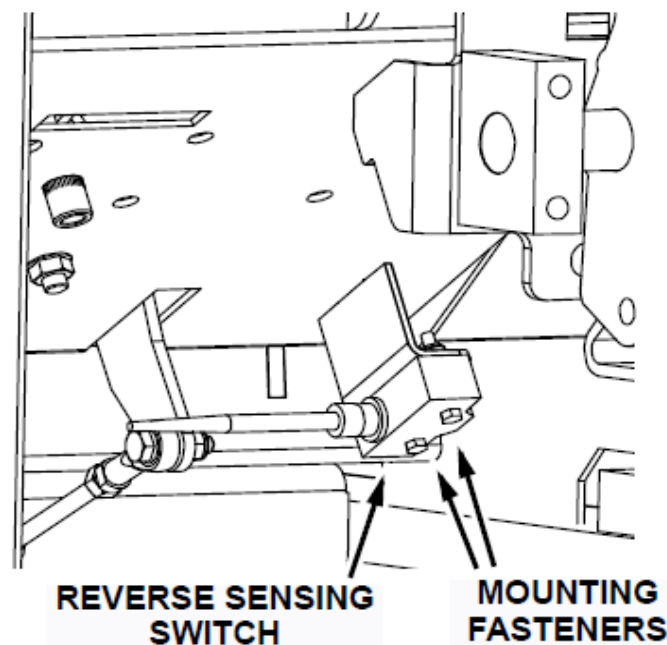

Fig. 1: Reverse Sensing Switch Fasteners

TROUBLESHOOTING

This section provides information to assist in identifying maintenance trouble and provides possible causes and actions to correct the problem. Many of the solutions require servicing your machine. Service must be performed by an approved authorized repair station.

TROUBLESHOOTING CHART		
PROBLEM	POSSIBLE CAUSE(S)	SOLUTION(S)
Engine will not start or runs roughly after start. NOTE: On machines with LPG fuel, also check the following:	Battery dead.	Recharge or replace battery.
	Machine out of fuel.	Refuel
	Fuel filter plugged.	Clean or replace filter.
	Fuel line broken or obstructed.	Blow fuel line out with compressed air.
	Dirty air filter.	Clean or replace air filter.
	Problems with spark plugs, ignition points, ignition coil ignition switch, carburetor, Regulator, wiring harness.	Review engine manual for maintenance and troubleshooting procedures.
	Tank valve not fully opened.	Open the valve slowly.
	Fuel tank type does not match fuel supply.	Use the correct tank type for the fuel supply.
	Fuel tank and lines are covered with frost.	Open shut-off valve slowly to ¼ open, start.
Defective vacuum lock-off.	Replace or repair.	

TROUBLESHOOTING CHART

PROBLEM	POSSIBLE CAUSE(S)	SOLUTION(S)
Engine overheats. NOTE: If coolant loss has not occurred, check for malfunction of the temperature sending unit.	Low coolant level.	Supply coolant.
	Fan blade installed incorrect	Reinstall (pusher type fan)
	Clogged radiator.	Flush radiator.
	Loose fan belt.	Tighten belt.
	Defective thermostat.	Replace thermostat.
Nautilus® moves slowly or does not move.	Parking brake is on.	Release brake.
	Directional control pedal jammed, damaged, or not adjusted properly.	Clear jam or adjust linkage.
	Tow valve in tow position	Move to drive position
	Low hydraulic fluid level.	Add hydraulic fluid.
	Hydraulic fluid temperature too high and too thin caused by excessive load, climbing, high environment temperatures, worn pump, or improper fluid.	Use the proper weight oil for the operation conditions; check pump.
	Hayes coupler failed	Replace
	Other problems with the hydraulics system: pump failure, motor failure, relief valve leaking or stuck open.	See Hydraulics System Problems in this section.
	Tow Valve improperly set.	Turn to correct position.

TROUBLESHOOTING CHART

PROBLEM	POSSIBLE CAUSE(S)	SOLUTION(S)
Nautilus® creeps in neutral.	Directional control pedal Neutral Sensing Switch is out of adjustment.	Perform the adjustment procedures.
Brushes do not turn or turn very slowly.	Hydraulic system problem:	See Hydraulics System Problems in this section.
	Motor	
	Control valve	
	Gear pump	
	Relief valve	
	Brush switch not on	Press to on position
	Foot pedal not depressed	Press to forward position
Scrub head will not lower.	Fuse blown.	Replace fuse.
	Loose scrub head switch wires.	Connect wires.
	Loose connection of plug at actuator.	Connect.
	Defective cylinder.	Replace cylinder.
	Defective scrub head switch.	Replace switch.
	Defective solenoid valve.	Replace solenoid valve or coil.

TROUBLESHOOTING CHART

PROBLEM	POSSIBLE CAUSE(S)	SOLUTION(S)
Poor water pick-up	Recovery tank is full.	Empty the tank; if foaming badly, change detergent.
	Squeegee worn.	Replace squeegee.
	Debris caught in squeegee or pick-up tube.	Remove debris.
	Leak or clog in hose from impeller.	Repair leak, clear obstruction or replace hose.
	Squeegee out of adjustment.	Adjust squeegee.
	Engine not operating at high speed.	Check Throttle Switch Position
	Impeller failure.	Check and repair.
Solution not being delivered.	Solution tank is empty.	Fill tank.
	Solution flow valve not functioning	Check broom switch & pressure switches @ main pump
	Delivery lines clogged.	Clear lines.
	Fwd/Rev Pedal not depressed	Press pedal

TROUBLESHOOTING CHART

PROBLEM	POSSIBLE CAUSE(S)	SOLUTION(S)
Scrubber unit not cleaning the floor.	Brushes worn.	Replace.
	Need different type of brush or detergent.	Use manufacturer's recommended brushes / detergent.
	Debris caught in brush drive mechanism.	Clear obstruction.
	Brushes out of adjustment.	Adjust.
	Brush motor failure.	See Hydraulics System Problems.
Squeegee will not lower.	Loose or defective squeegee switch (on console).	Reconnect wiring or replace switch.
	Loose wire(s) at foot pedal.	Connect.
	Foot pedal switches need adjustment.	Re-adjust cams.
Squeegee will not raise in reverse or by console switch.	Foot pedal switches need adjustment.	Re-adjust cams.
	Defective solenoid valve.	Replace solenoid valve or coil
	No power at valve.	Check fuse

TROUBLESHOOTING CHART

PROBLEM	POSSIBLE CAUSE(S)	SOLUTION(S)
Scrubber leaving debris.	Hopper full.	Dump hopper.
	Brushes out of adjustment.	Adjust.
	Brushes bristles worn.	Check for wear and adjustment.
	Poor performance of brush drive mechanism.	Check for jam in broom chamber.
	Hopper flaps damaged or missing.	Replace or adjust clearance.
Hydraulic control valve failure	Defective solenoid valve.	Replace solenoid valve or coil.
	Switch failure.	Check for loose or disconnected wires.

TROUBLESHOOTING CHART

PROBLEM	POSSIBLE CAUSE(S)	SOLUTION(S)
Hydraulic drive motor failure.	Insufficient oil supply	Fill Reservoir
	Motor leaking.	Replace seals.
	Drive pump coupler failed	Replace
	Key on motor shaft failed	Replace key
	Drive hub failed	Replace
Hydraulic gear pump failure.	Pump leaking.	Replace seals or RR Pump
	Drive coupler failed	Replace
	Gears worn or scored.	Rebuild pump or RR Pump
	Oil supply low.	Check and fill.
	Oil strainer clogged.	Replace strainer (inside reservoir).
	Incorrect oil.	Use recommended viscosity oil.
	Damage due to entry of air into hydraulic system.	Maintain correct hydraulic fluid level in reservoir. Keep suction hose fittings tight..

TROUBLESHOOTING CHART		
PROBLEM	POSSIBLE CAUSE(S)	SOLUTION(S)
Hydraulic variable displacement pump failure.	Pump leaking.	Replace seals.
	Relief valve(s) stuck.	Clean or replace relief valve(s) at the pump.
	Drive coupling malfunction.	Replace defective gears.
	Control linkage out of adjustment.	Adjust control linkage, check for binding.
	Charge pump gears worn or scored.	Replace defective gears.
	Damage due to entry of air into hydraulic system.	Maintain correct hydraulic fluid level in reservoir. Keep suction hose fittings tight.
Hydraulic system noisy.	Air in system.	Check fluid level in reservoir; check for loose connections or leaks.
	Relief valve dirty or damaged.	Clean or replace.
	Loose suction line.	Tighten fittings.
	Clogged section filter or pump inlet line.	Replace filter, clear line; change fluid in reservoir if dirty and flush system.
	Internal pump or motor damage.	Inspect and repair.

NAUTILUS MAIN BRUSH AND IMPELLER PRESSURE RELIEF ADJUSTMENTS

These adjustments are necessary if the hydraulic manifolds are supplied with the relief valves set at zero or incorrectly set.

MAIN BRUSH PRESSURE RELIEF ADJUSTMENT:

- Install an appropriate pressure gauge at the gauge port on the main hydraulic manifold. The gauge port (GA) is located on the left side of the manifold when viewed from the front of the machine.
- Disconnect the electrical connection to the main brush solenoid SV3 located in the lower left manifold port 3.2 (after the first 5 prototypes the 3.2 port location will be embossed as 10). This will block the flow out of the manifold and force the fluid flow to go over the relief valve RV2.
- Loosen the lock nut and unscrew the pressure adjustment screw on the pressure relief valve RV2. This will allow all of the fluid flow to pass at low pressure through the relief valve.
- Start the machine and switch the engine throttle switch to operating (high) speed.
- Turn on the brushes.
- Turn the pressure relief adjustment screw in (clockwise) while monitoring the hydraulic pressure on the pressure gauge. When the gauge reads 2500 psi (it will vary a little, and that is OK) tighten the adjustment screw lock nut and turn off the engine.

NOTE: Perform the adjustment as quickly as possible. During this set up do not run the machine for an extended period of time after the pressure relief is set as the hydraulic oil will generate excessive heat when going through the pressure relief valve.

- Reconnect the electrical connection to the SV3 solenoid.

This completes the main brush pressure relief adjustment.

NAUTILUS MAIN BRUSH AND IMPELLER PRESSURE RELIEF ADJUSTMENTS

IMPELLER PRESSURE RELIEF ADJUSTMENT:

Install an appropriate pressure gauge at the gauge port on the impeller hydraulic manifold. The gauge port (GA) is located on the face of the manifold when viewed from the front of the machine.

In order to force the hydraulic fluid through the relief valve it is necessary to block the flow from the manifold to the impeller.

- Remove the hydraulic hose from the outlet of the hydraulic manifold at port VF OUT located on the top of the manifold and plug (pressure tight) the fitting on the manifold and the end of the hose.
- Loosen the lock nut and unscrew the pressure adjustment screw on the pressure relief valve RV1 located in port 9.2. This will allow all of the fluid flow to pass at low pressure through the relief valve.
- Start the machine and switch the engine throttle switch to operating (high) speed.
- Turn on the impeller.
- Turn the pressure relief adjustment screw in (clockwise) while monitoring the hydraulic pressure on the pressure gauge.

When the gauge reads 2500 psi (it will vary a little, you will probably not get it to read exactly 2500 and that is OK) tighten the adjustment screw lock nut and turn off the engine.

NOTE: Perform the adjustment as quickly as possible. During this set up do not run the machine for an extended period of time after the pressure relief is set as the hydraulic oil will generate excessive heat when going through the pressure relief valve.

- Reconnect the hydraulic hose to the impeller solenoid.

This completes the main brush pressure relief adjustment.

NAUTILUS SCRUB BRUSH FLOOR PRESSURE ADJUSTMENT

Before the scrub head floor pressure adjustment can be performed the reduction valve at the main hydraulic manifold port 4.1 must be adjusted to 450 psi (The purpose of this valve is to change the variable inlet pressure (approximately 700 psi) to a constant output pressure of 450 psi which is applied to the piston-end of the scrub head lift cylinder. 450 psi is the pressure required to raise the scrub head at full engine rpm).

If this valve has already been adjusted go to “Setting the scrub brush floor pressure controller”.

To adjust the reduction valve at port 4.1:

- Install a tee fitting with a gauge port between the main hydraulic hose and the hydraulic manifold at port BLA.
- Attach a suitable hydraulic pressure gauge to the gauge port in the tee fitting.
- Zero the pressure gauge if necessary.
- Loosen the lock nut on the adjustment stud on the reduction valve located on the main hydraulic manifold at port 4.1
- Ensure that the green “One-Touch” switch is in the off position.
- Start the engine
- Set the throttle switch to high.
- Turn the reduction valve adjustment stud clockwise until the pressure gauge reads 450 psi.

(Note: It is not possible to attain 450 psi if the restrictor orifice fitting is not installed at the power steering unit pressure port.)

- Tighten the reduction valve locknut.
- Verify the pressure reading.
- Turn off the engine.
- Replace the hydraulic hose at port BLA.

NAUTILUS SCRUB BRUSH FLOOR PRESSURE ADJUSTMENT

Setting the scrub brush floor pressure controller (proportional valve driver)

The floor brush pressure controller (located on the left front face of the operator console) provides three separate brush floor pressure forces by controlling the hydraulic pressure output of the proportional reduction valve located on the main hydraulic manifold at port 6.1. This variable output pressure is applied to the rod-end of the scrub head lift cylinder. This variable pressure is balanced against the steady 450 psi provided by the reduction valve (above) to achieve the desired scrub brush floor pressure. The controller has a left control knob, a right control knob, and an information screen. The right control knob scrolls between the various setting titles. The left control knob provides input settings.

Description of the adjustable parameters:

P1 – The low brush floor pressure setting.

P2 – The medium brush floor pressure setting

P3 – The high brush floor pressure setting

P4 – The P4 setting is not used. (Any number input will have no effect.)

J9 – Jog. This is used to simulate a P1 – P3 setting and its effect on the brush pressure in real time. (This does not require an input setting.)

UP - The ramp time required for the output signal to increase by 1 amp.

dn - The ramp time required for the output signal to decrease by 1 amp.

dF – Dither frequency. (Dither is an oscillation feature that eliminates slip stick in the operation of the solenoid.)

di – Display orientation

SA – Save settings

NAUTILUS SCRUB BRUSH FLOOR PRESSURE ADJUSTMENT

The unit must be on to input settings.

Turning the right control knob scrolls through the parameters listed above.

Turning the left control knob changes the settings of each parameter.

The settings are saved by turning the right control knob to SA and rotating the left control knob one full turn (in either direction).

CONTROLLER SETTINGS:

Set P1 to 1.52 A Providing 200 lbs of brush pressure against the floor (415 psi at port BLB)

Set P2 to 1.75 A Providing 300 lbs of brush pressure against the floor (730 psi at port BLB)

Set P3 to 1.92 A Providing 400 lbs of brush pressure against the floor (865 psi at port BLB)

P4 – 0.00 A

Set UP to 00.5 SEC

Set DN to 00.5 SEC

Set Df (dither) to 60 Hz

dl = screen orientation – no setting should be required.

SA (save settings) – Turn the left control knob one full turn (in either direction).

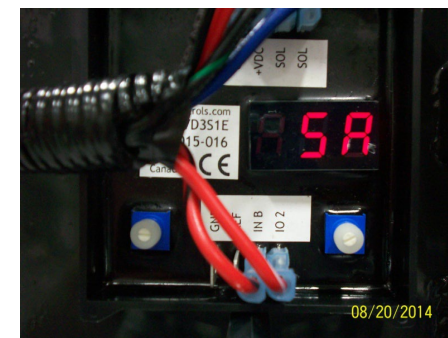
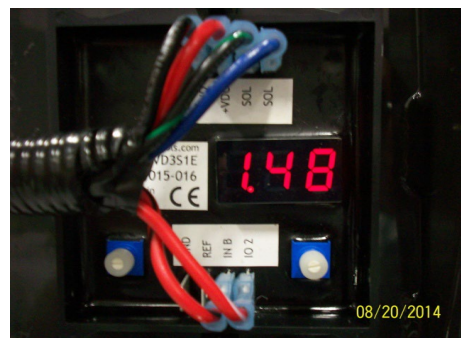

ADJUSTMENTS & PROCEDURES WITH OPTIONAL SIDE SCRUB

NAUTILUS DUAL CONTROLLER ADJUSTMENT FOR MAIN SCRUB BRUSH AND OPTIONAL SIDE SCRUB BRUSH FLOOR PRESSURE ADJUSTMENT.

Before the scrub head floor pressure adjustment can be performed the reduction valve at the main hydraulic manifold port 4.1 must be adjusted to 450 psi (The purpose of this valve is to change the variable inlet pressure (approximately 700 psi) to a constant output pressure of 450 psi which is applied to the piston-end of the scrub head lift cylinder. 450 psi is the pressure required to raise the scrub head at full engine rpm).

If this valve has already been adjusted go to “Setting the scrub brush floor pressure controller”.

To adjust the reduction valve at port 4.1:

- Install a tee fitting with a gauge port between the main hydraulic hose and the hydraulic manifold at port BLA.
- Attach a suitable hydraulic pressure gauge to the gauge port in the tee fitting.
- Zero the pressure gauge if necessary.
- Loosen the lock nut on the adjustment stud on the reduction valve located on the main hydraulic manifold at port 4.1
- Ensure that the green “One-Touch” switch is in the off position.
- Start the engine
- Set the throttle switch to high.
- Turn the reduction valve adjustment stud clockwise until the pressure gauge reads 450 psi.

(Note: It is not possible to attain 450 psi if the restrictor orifice fitting is not installed at the power steering unit pressure port.)

- Tighten the reduction valve locknut.
- Verify the pressure reading.
- Turn off the engine.
- Replace the hydraulic hose at port BLA.

Setting the main scrub brush floor pressure (Using the dual proportional valve driver)

The dual floor brush pressure controller (located on the left front face of the operator console) provides three separate brush floor pressure forces for the main scrub brushes by controlling the hydraulic pressure output of the SV4 proportional reduction valve located on the main hydraulic manifold at port 6.1. and provides three separate brush floor pressure forces for the side scrub brush by controlling the hydraulic pressure output of the SV9 proportional reduction valve located on the SSB hydraulic manifold at port 6.2.

For the main scrub brushes this variable output pressure is applied to the rod-end of the scrub head lift cylinder. This variable pressure is balanced against the steady 450 psi provided by the reduction valve (above) to achieve the desired scrub brush floor pressure.

For the side scrub brush this variable output pressure is applied to the piston-end of the side scrub head lift cylinder. This variable pressure is balanced against the steady 450 psi provided by the reduction valve (above) to achieve the desired scrub brush floor pressure.

The controller has a left control knob, a right control knob, and an information screen.

The right control knob scrolls between the various setting titles.

The left control knob provides input settings.

Description of the adjustable parameters:

BP1 – The low brush floor pressure setting.

BP2 – The medium brush floor pressure setting

BP3 – The high brush floor pressure setting

BP4 – The BP4 setting is not used. (Any number input will have no effect.)

BJ9 – Jog. This is used to simulate a P1 – P3 setting and its effect on the brush pressure in real time. (This does not require an input setting.)

BUP - The ramp time required for the output signal to increase by 1 amp.

Bdn - The ramp time required for the output signal to decrease by 1 amp.

DF – Dither frequency. (Dither is an oscillation feature that eliminates slip stick in the operation of the solenoid.)

di – Display orientation

SA – Save settings

The unit must be “on” to input settings.
Turning the right control knob scrolls through the parameters listed above.
Turning the left control knob changes the settings of each parameter.
The settings are saved by turning the right control knob to SA and rotating the left control knob one full turn (in either direction).



DUAL CONTROLLER “B” (MAIN SCRUB BRUSH) SETTINGS:

Set BP1 to 1.52 A Providing 200 lbs of main brush pressure against the floor (415 psi at port BLB)

Set BP2 to 1.75 A Providing 300 lbs of main brush pressure against the floor (730 psi at port BLB)

Set BP3 to 1.98 A Providing 400 lbs of main brush pressure against the floor (865 psi at port BLB)

BP4 – 0.00 A

Set BUP to 00.5 SEC

Set BDN to 00.5 SEC

Set Df (dither) to 60 Hz

dI = screen orientation – no setting should be required.

SA (save settings) – Turn the left control knob one full turn (in either direction).



Setting the side scrub brush floor pressure (Using the dual proportional valve driver)

The dual floor brush pressure controller (located on the left front face of the operator console) provides three separate side brush floor pressure forces by controlling the hydraulic pressure output of the proportional reduction valve located on the SSB hydraulic manifold at port 6.2.

This variable output pressure is applied to the piston-end of the side scrub head lift cylinder. This variable pressure is balanced against the steady 450 psi provided by the reduction valve (above) to achieve the desired side scrub brush floor pressure.

The controller has a left control knob, a right control knob, and an information screen.

The right control knob scrolls between the various setting titles.

The left control knob provides input settings.

Description of the side scrub brush adjustable parameters:

The dual controller uses an “A” prefix for the optional side brush settings and a “B” prefix for the Main brush settings.

BP1 through BP4 control the low, medium, and high main scrub brush floor pressure.

These along with BUP, Bdn, and dF parameters should be set using the information shown in the NAUTILUS SCRUB BRUSH FLOOR PRESSURE ADJUSTMENT instructions.

AP1 – The low side brush floor pressure setting.

AP2 – The medium side brush floor pressure setting

AP3 – The high side brush floor pressure setting

AP4 – The P4 setting is not used. (Any number input will have no effect.)

AJ9 – Jog. This is used to simulate a AP1 – AP3 setting and its effect on the side brush pressure in real time. (This does not require an input setting.)

AUP - The ramp time required for the output signal to increase by 1 amp.

Adn - The ramp time required for the output signal to decrease by 1 amp.

dF – Dither frequency. (Dither is an oscillation feature that eliminates slip stick in the operation of the solenoid.)

di – Display orientation

SA – Save settings

The unit must be on to input settings.

Turning the right control knob scrolls through the parameters listed above.

Turning the left control knob changes the settings of each parameter.

The settings are saved by turning the right control knob to SA and rotating the left control knob one full turn (in either direction).

DUAL CONTROLLER "A" (SIDE SCRUB BRUSH) SETTINGS:

Set AP1 to 1.60 A Providing 120 lbs of brush pressure against the floor

Set AP2 to 1.70 A Providing 130 lbs of brush pressure against the floor

Set AP3 to 1.85 A Providing 140 lbs of brush pressure against the floor

AP4 – 0.00 A

Set AUP to 00.5 SEC

Set ADN to 00.5 SEC

Set Df (dither) to 60 Hz

dl = screen orientation – no setting should be required.

SA (save settings) – Turn the left control knob one full turn (in either direction).



O-RING FACE SEAL ASSEMBLY TORQUES AND FFWR

O.D.		SAE DASH SIZE	TUBE SIDE THREAD SIZE	ASSEMBLY TORQUE (+10%-0)			FLATS FROM WRENCH RESISTANCE(FFWR)		
(IN.)	(MM)			IN.-LB	FT.-LB	N-M	TUBE NUTS	SWIVEL AND HOSE	
1/4	6	-4	9/16-18	220	18	25	1/4 TO 1/2	1/2 TO 3/4	
3/8	8,10	-6	11/16-16	360	30	40	1/4 TO 1/2	1/2 TO 3/4	
1/2	12	-8	13/16-16	480	40	55	1/4 TO 1/2	1/2 TO 3/4	
5/8	14,15,16	-10	1-14	-	60	80	1/4 TO 1/2	1/2 TO 3/4	
3/4	18,20	-12	1 3/16-12	-	85	115	1/4 TO 1/2	1/3 TO 1/2	
1	22,25	-16	1 7/16-12	-	110	150	1/4 TO 1/2	1/3 TO 1/2	
1 1/4	28,30,32	-20	1 11/16-12	-	150	205	1/4 TO 1/2	1/3 TO 1/2	
1 1/2	35,38	-24	2-12	-	230	315	1/4 TO 1/2	1/3 TO 1/2	

BRUSHES
PRESSURE RELIEF 2500
PSI

IMPELLER
PRESSURE RELIEF
2500 PSI

WHEEL DRIVE
PRESSURE RELIEF
4000 PSI

PWR STEERING UNIT
PRESSURE RELIEF
1200 PSI

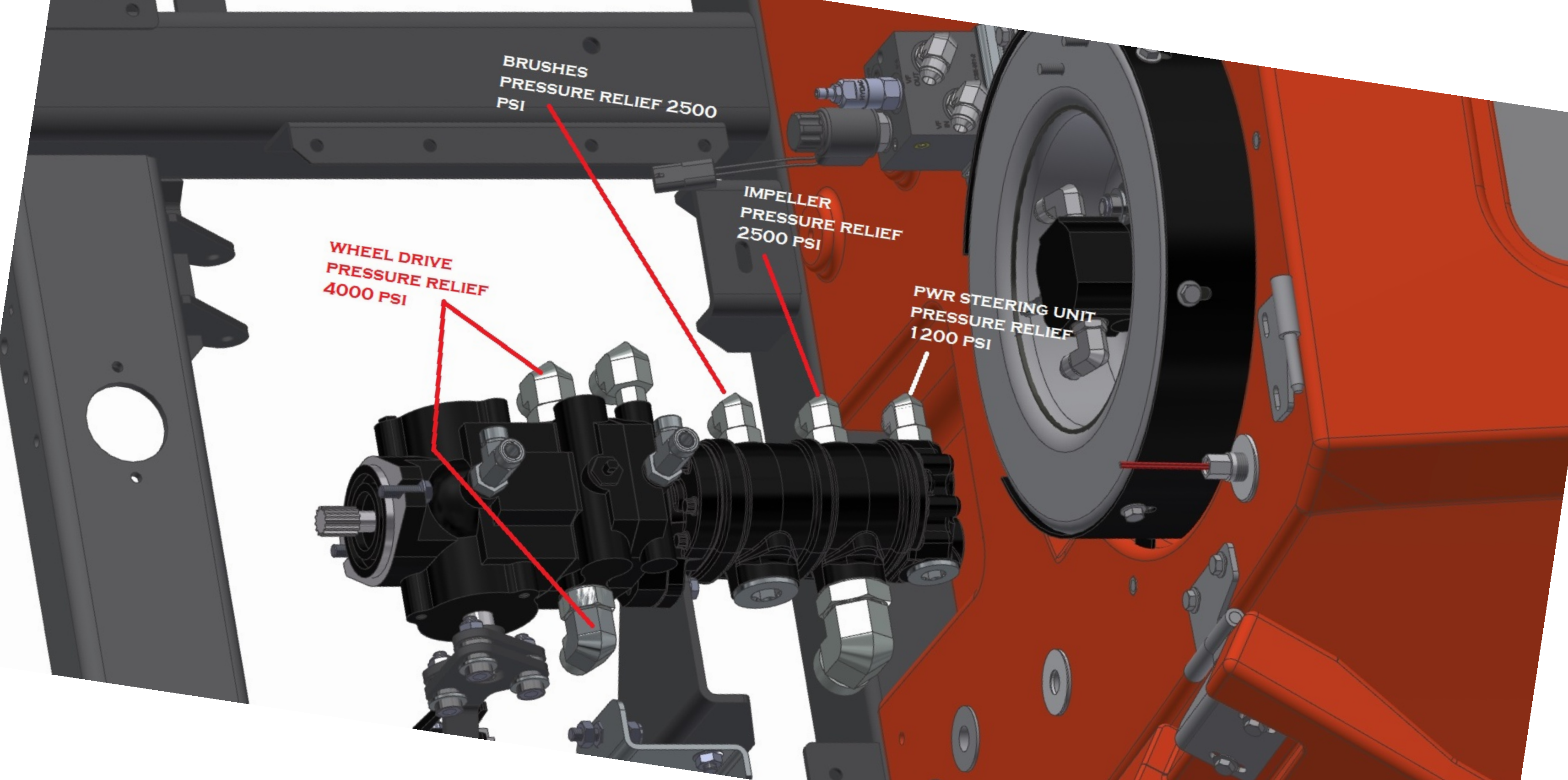

SSB HYDRAULIC MANIFOLD COMPONENTS

730171 For Optional Side Broom

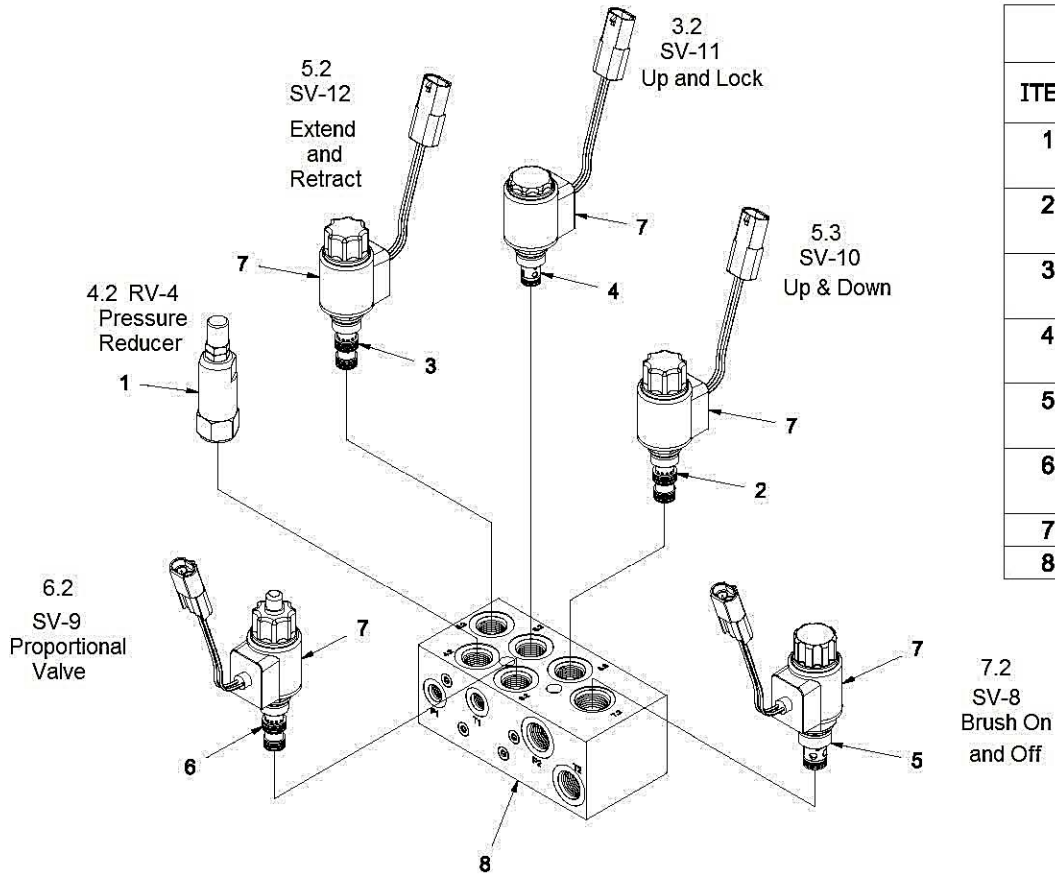

Parts List 730171

ITEM	PART NUMBER	QTY	DESCRIPTION
1	730702	1	PORT 4.2 - RV4 - PRESSURE REDUCTION VALVE SOL. RED. VALVE, DR08-01-C-N-050-V-45
2	730705	1	PORT 5.3 - SV10 - SIDE BRUSH DOWN SOL. VALVE, WK08L-01-C-N-0
3	730705	1	PORT 5.2 - SV12 - SIDE BRUSH EXTEND SOL. VALVE, WK08L-01-C-N-0
4	730707	1	PORT 3.2 - SV11 - SIDE BRUSH UP - LOCK SOL. VALVE, WS08ZR-01-C-N-0
5	730709	1	PORT 7.2 - SV8 - SIDE BRUSH ON SOL. VALVE, WS10Y-01-C-N-0
6	730710	1	PORT 6.2 - SV9 - SIDE BRUSH FORCE PROP. RED. VALVE, PDR08-01-M-C-N-070-12PW-2.2
7	731122	5	COIL, 12V, 3003124
8	731123	1	MANIFOLD BLOCK, SSB

REV A

**NAUTILUS HIGH DUMP
HYDRAULIC/ELECTRICAL
MANIFOLD ILLUSTRATION**

5.1 HOPPER LOWER

5.2 HOPPER LIFT

5.3 BUMPER LOWER

5.4 BUMPER LIFT

2 HOPPER DOOR

R-1, LATCH RELAY



R-3, HOPPER RELAY

R-2, BUMPER RELAY

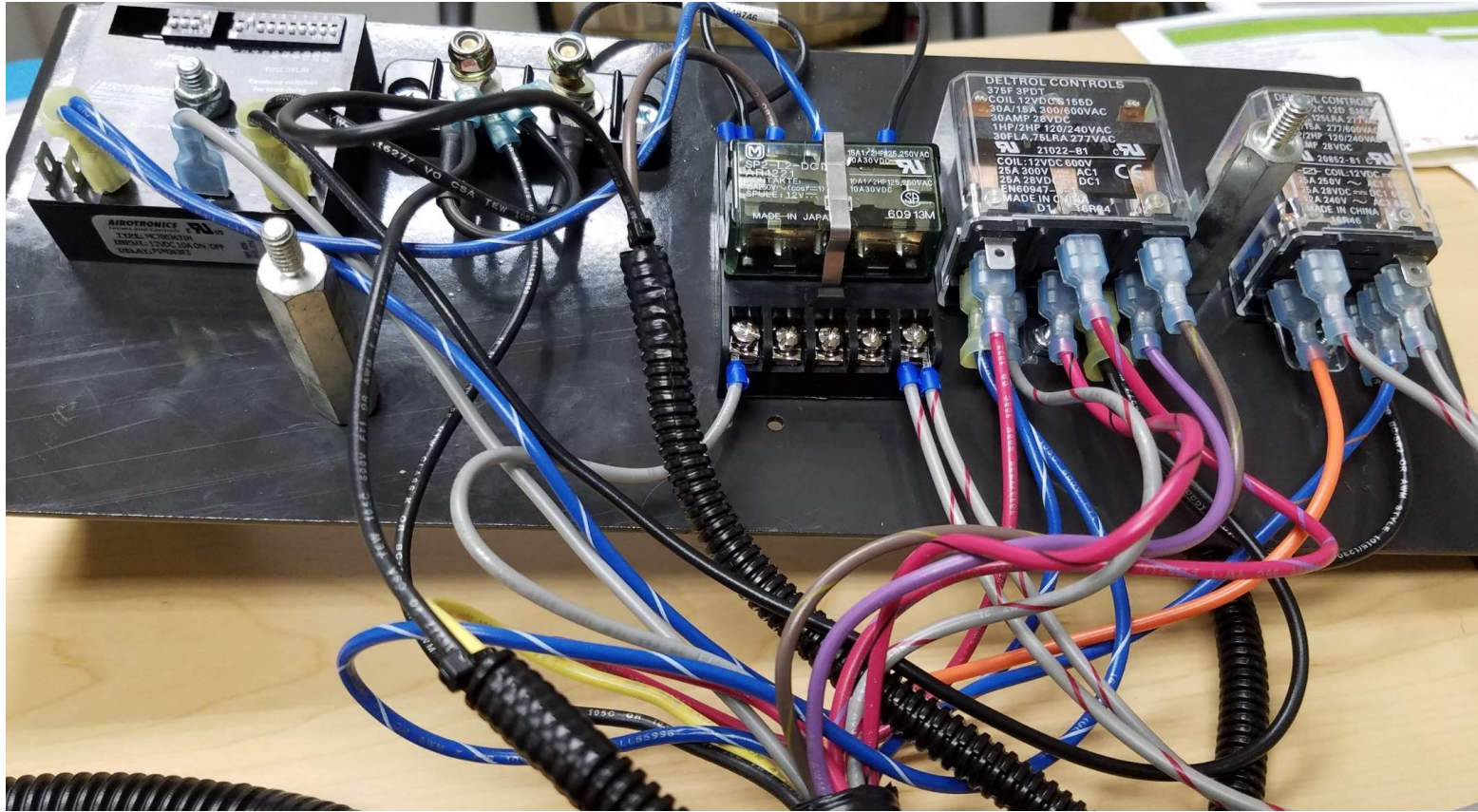

HOPPER TIMER (T-8)



R-1, LATCH RELAY

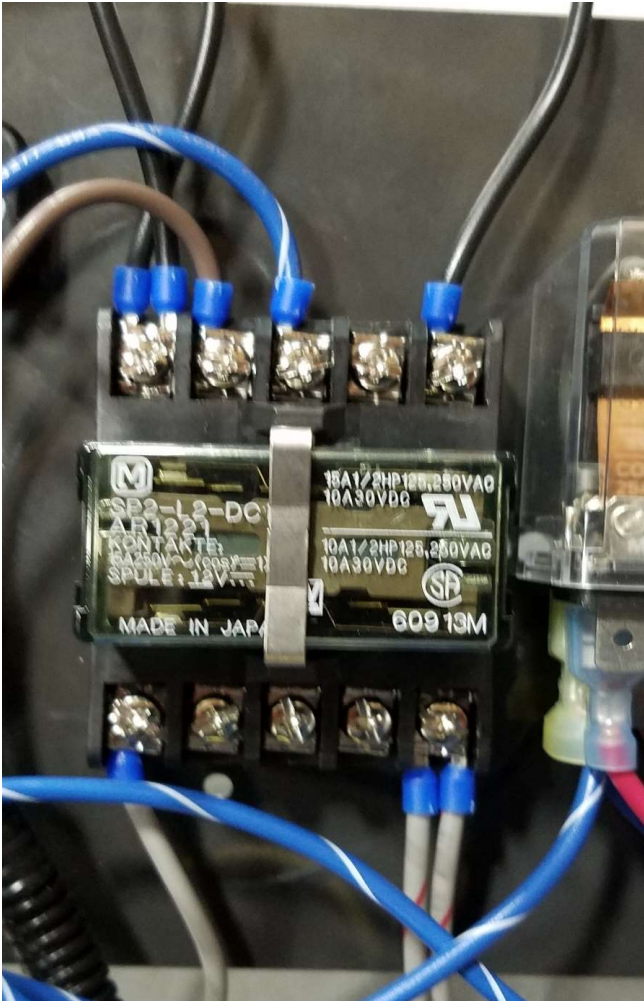

R-3, HOPPER RELAY

R-2, BUMPER RELAY

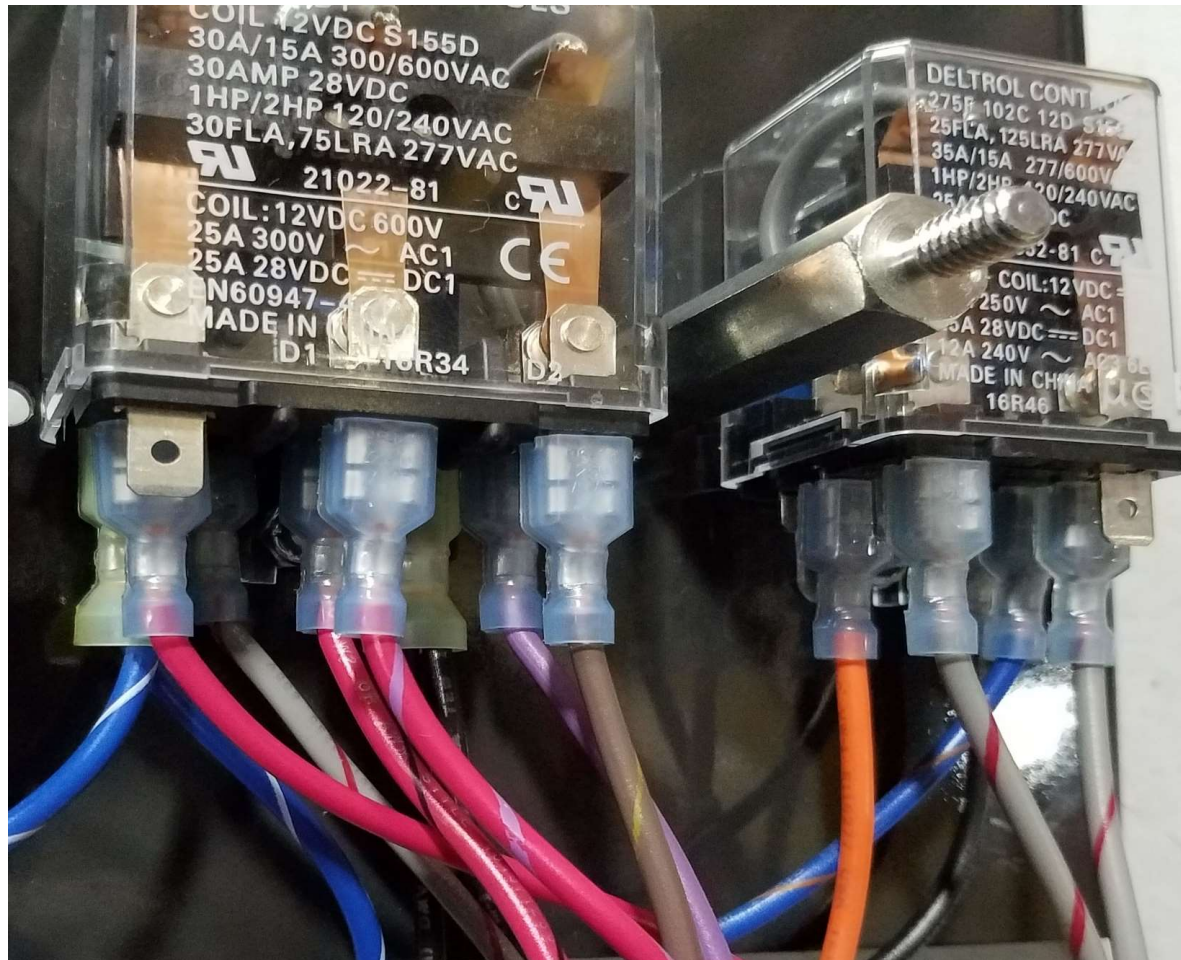

NAUTILUS HD

FROM SHEET 3

FROM SHEET 3

5/RED

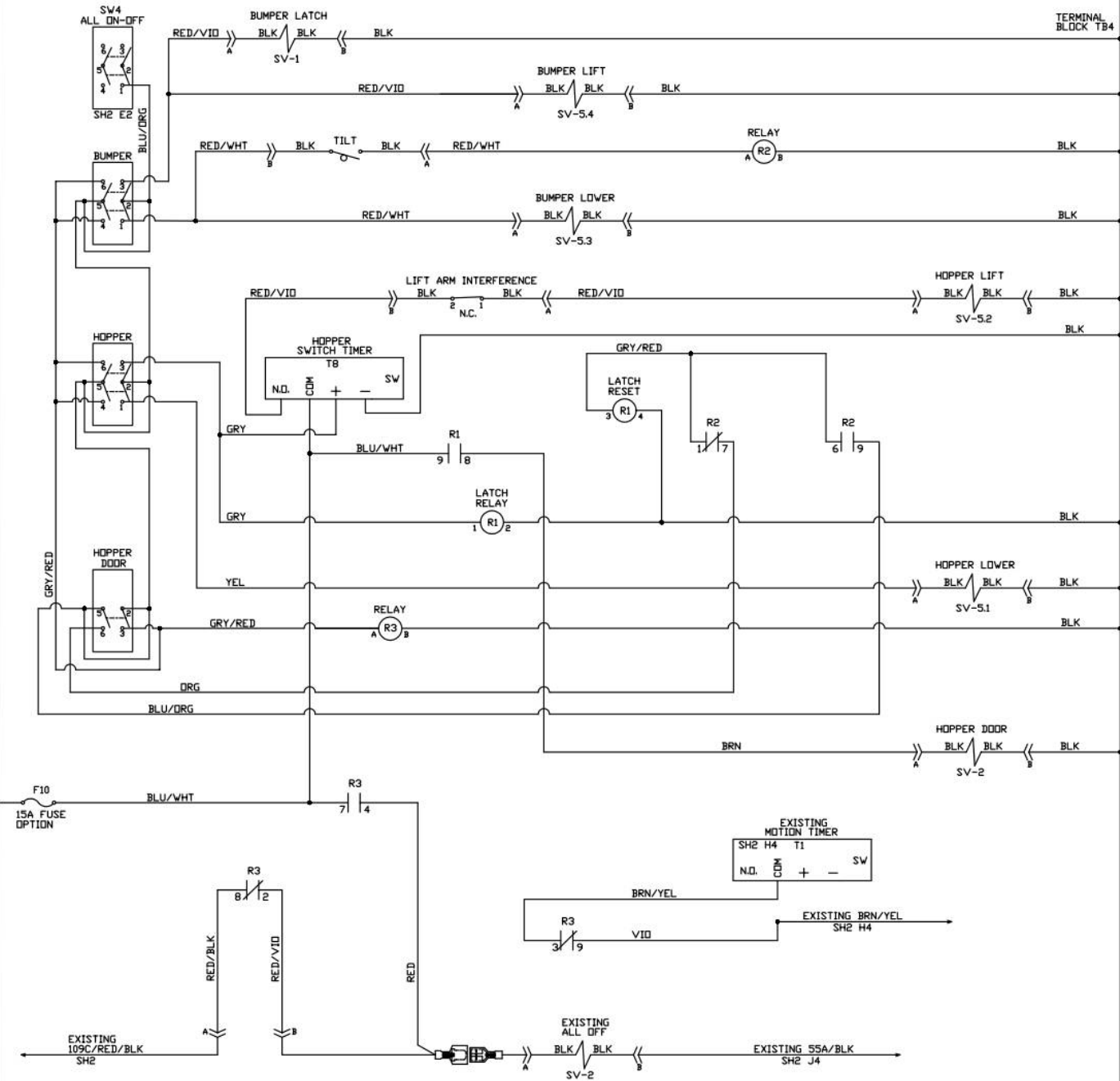

HIGH DUMP HYDRAULIC HOSE GROUP

770118

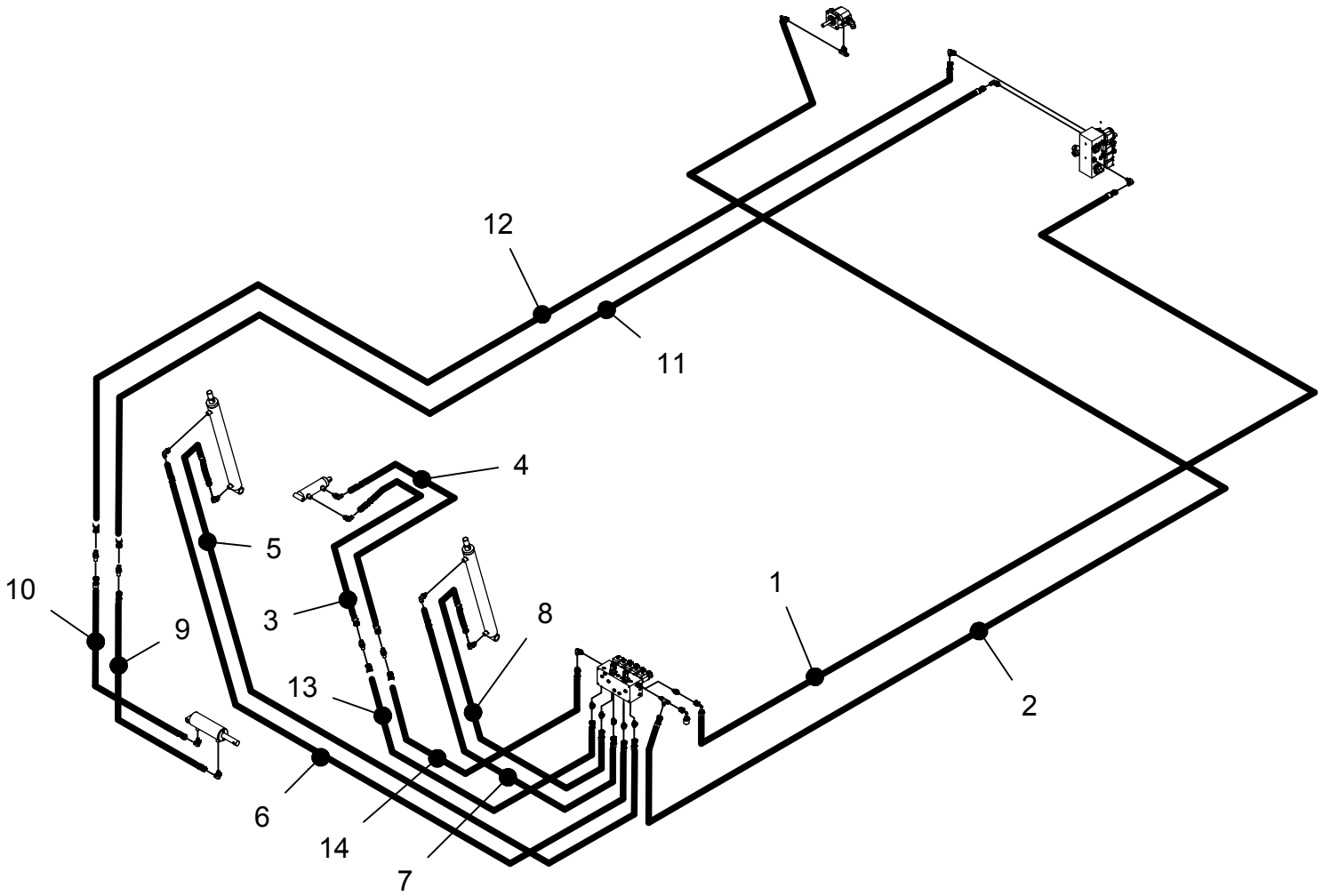

REV B

HIGH DUMP HYDRAULIC HOSE GROUP

770118

Parts List 770118			
ITEM	PART NUMBER	QTY	DESCRIPTION
1	770568	1	HOSE, 4 STR - 4 90 (VALVE PB TO HD VALVE P)
2	770569	1	HOSE, 4 STR - 4 90 (HD VALVE T TO IMP CASE L)
3	770570	1	HOSE, 4 STR - 4 STR (DOOR CYL R TO R PILLAR LH BULKHD)
4	770571	1	HOSE, 4 STR - 4 STR (DOOR CYL F TO R PILLAR RH BULKHD)
5	770572	1	HOSE, 4 STR - 4 STR (HD VALVE SAL A TO B- LIFT CYL L)
6	770573	1	HOSE, 4 STR - 4 STR (HD VALVE SAL B TO B-LIFT CYL U)
7	770574	1	HOSE, 4 STR - 4 STR (HD VALVE HL B TO H-LIFT CYL U)
8	770575	1	HOSE, 4 STR - 4 STR (HD VALVE HL A TO H-LIFT CYL L)
9	770576	1	HOSE, 4 STR - 4 STR (SQU CYL R TO L PILLAR RH BULKHD)
10	770577	1	HOSE, 4 STR - 4 STR (SQU CYL L TO L PILLAR LH BULKHD)
11	770584	1	HOSE, 4 STR -4 STR (L PILLAR RH BULKHD TO VALVE SG A)
12	770585	1	HOSE, 4 STR -4 STR (L PILLAR LH BULKHD TO VALVE SG B)
13	770586	1	HOSE, 4 STR -4 STR (R PILLAR LH BULKHD TO VALVE HD B)
14	770587	1	HOSE, 4 STR -4 STR (R PILLAR RH BULKHD TO VALVE HD A)

REV B

HIGH DUMP HYDRAULIC HOSE ROUTING

770119

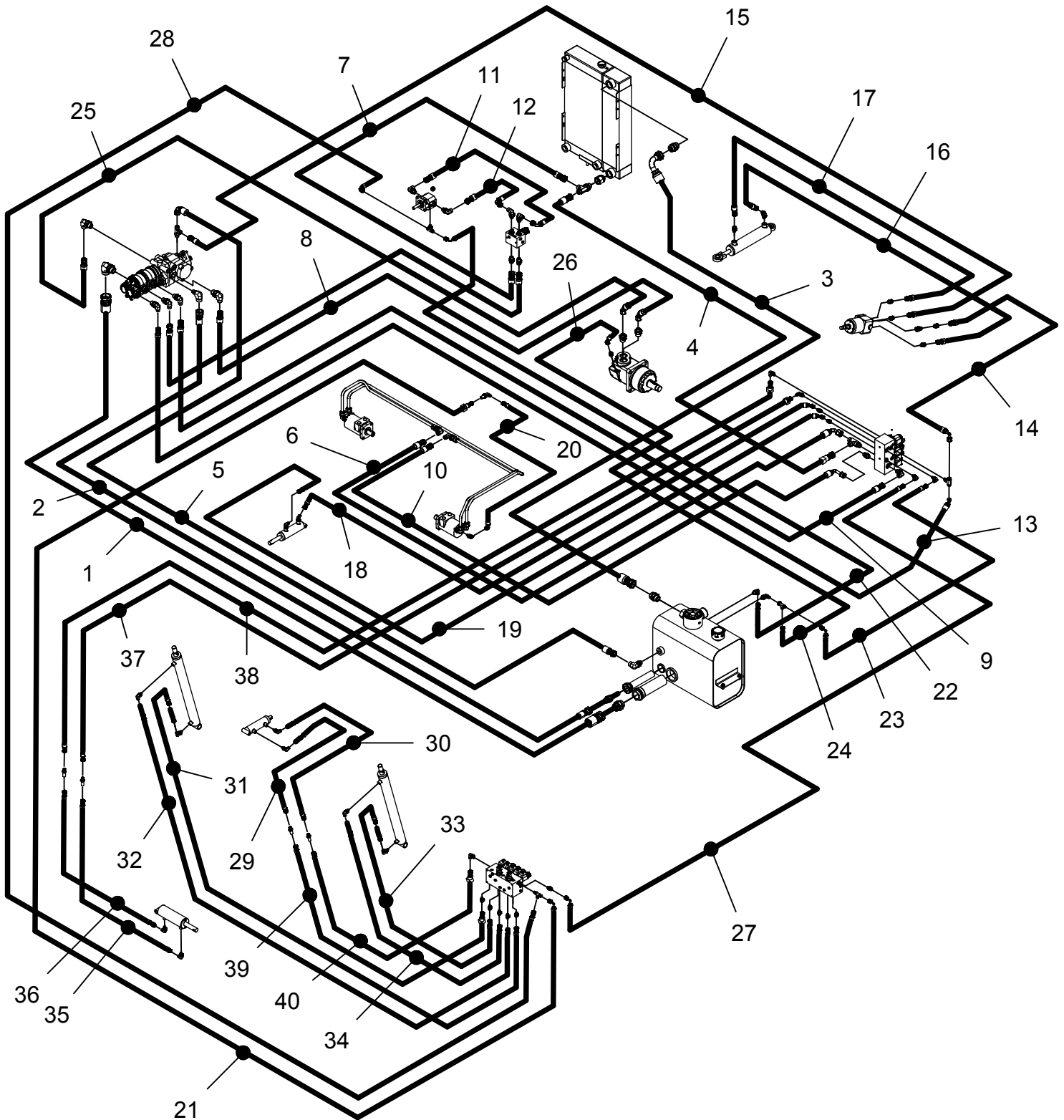

REV B

HIGH DUMP HYDRAULIC HOSE ROUTING 770119

Parts List 770119			
ITEM	PART NUMBER	QTY	DESCRIPTION
1	731051	1	HOSE, 20 STR - 20 STR SUC (RES TO AUX PUMP IN)
2	731052	1	HOSE, 12 STR - 12 STR SUC (RES TO VDP CASE)
3	731053	1	HOSE, 16 STR - 16 90 RET (COOLER UPPER TO RES)
4	731054	1	HOSE, 10 STR - 10 STR RET (VALVE T2 TO COOLER)
5	731055	1	HOSE, 10 STR - 8 90 RET (VDP CASE TO RES)
6	731056	1	HOSE, 8 STR - 10 90 MED (MB LEFT TO VALVE T2)
7	731057	1	HOSE, 8 STR - 10 STR MED (IMP SOL T TO COOLER)
8	731058	1	HOSE, 8 STR - 8 STR MED (AUX PUMP 2 TO IMP SOL P)
9	731059	1	HOSE, 8 STR - 8 STR MED (AUX PUMP 1 TO VALVE P2)
10	731060	1	HOSE, 8 STR - 8 90 MED (VALVE MB OUT TO MB RIGHT)
11	731061-1	1	HOSE, 6 STL - 6 90 (IMP SOL VF OUT TO IMP LEFT) S/N 12345 -
11	731061	1	HOSE, 8 STR - 8 90 (IMP SOL VF OUT TO IMP LEFT) TO S/N 12344
12	731062	1	HOSE, 8 STR - 8 90 MED (IMP RIGHT TO IMP SOL VF IN)
13	731063	1	HOSE, 6 STR - 6 45 MED (AUX PUMP 3 TO VALVE P1)
14	731064	1	HOSE, 6 STR - 6 90 MED (VALVE P1 TO STR PRESS)
15	731065	1	HOSE, 6 STR - 8 STR RET (STR TANK TO VDP CASE)
16	731066	1	HOSE, 6 STR - 6 STR MED (STR LEFT TO CYL F)
17	731067	1	HOSE, 6 STR - 6 STR MED (STR RIGHT TO CYL R)
18	731068	1	HOSE, 4 STR - 4 45 MED (VALVE BL A TO SH CYL F)
19	731069	1	HOSE, 4 STR - 4 45 MED (VALVE BL B TO SH CYL R)
20	731072	1	HOSE, 4 STR - 4 45 MED (MB CASE TO MB MOTOR)
21	731073	1	HOSE, 4 STR - 4 90 MED (MB CASE TO HD VALVE T)
22	731074	1	HOSE, 4 STR - 4 90 MED (IMP CASE TO RES)
23	731075	1	HOSE, 4 STR - 4 90 MED (VALVE T1 TO RES)
24	731076	1	HOSE, 4 STR - 4 45 MED (WHEEL DRIVE CASE TO RES)
25	731077	1	HOSE, 8 STR - 8 45 SPCL (VDP L TO WHEEL DRIVE R)
26	731078	1	HOSE, 8 STR - 8 45 SPCL (VDP R TO WHEEL DRIVE F)
27	770568	1	HOSE, 4 STR - 4 90 MED (VALVE PB TO HD VALVE P)
28	770569	1	HOSE, 4 STR - 4 90 MED (IMP CASE L TO HD VALVE T)
29	770570	1	HOSE, 4 STR - 4 STR MED (HD VALVE HD B TO DOOR CYL R)
30	770571	1	HOSE, 4 STR - 4 STR MED (HD VALVE HD A TO DOOR CYL F)
31	770572	1	HOSE, 4 STR - 4 STR MED (HD VALVE SAL A TO S-LIFT CYL L)
32	770573	1	HOSE, 4 STR - 4 STR MED (HD VALVE SAL B TO S-LIFT CYL U)
33	770574	1	HOSE, 4 STR - 4 STR MED (HD VALVE HL B TO H-LIFT CYL U)
34	770575	1	HOSE, 4 STR - 4 STR MED (HD VALVE HL A TO H-LIFT CYL L)
35	770576	1	HOSE, 4 STR - 4 STR MED (SQU CYL R TO L PILLAR RH BULKHD)
36	770577	1	HOSE, 4 STR - 4 STR MED (SQU CYL L TO L PILLAR LH BULKHD)
37	770584	1	HOSE, 4 STR -4 STR (L PILLAR RH BULKHD TO VALVE SG A)
38	770585	1	HOSE, -4STR -4 STR (L PILLAR LH BULKHD TO VALVE SG B)
39	770586	1	HOSE, 4 STR -4 STR (R PILLAR LH BULKHD TO VALVE HD B)
40	770587	1	HASE, 4 STR -4 STR (R PILLAR RH BULKHD TO VALVE HD A)

REV B

OPTIONAL SIDE BRUSH
HYDRAULIC HOSE ROUTING
730038

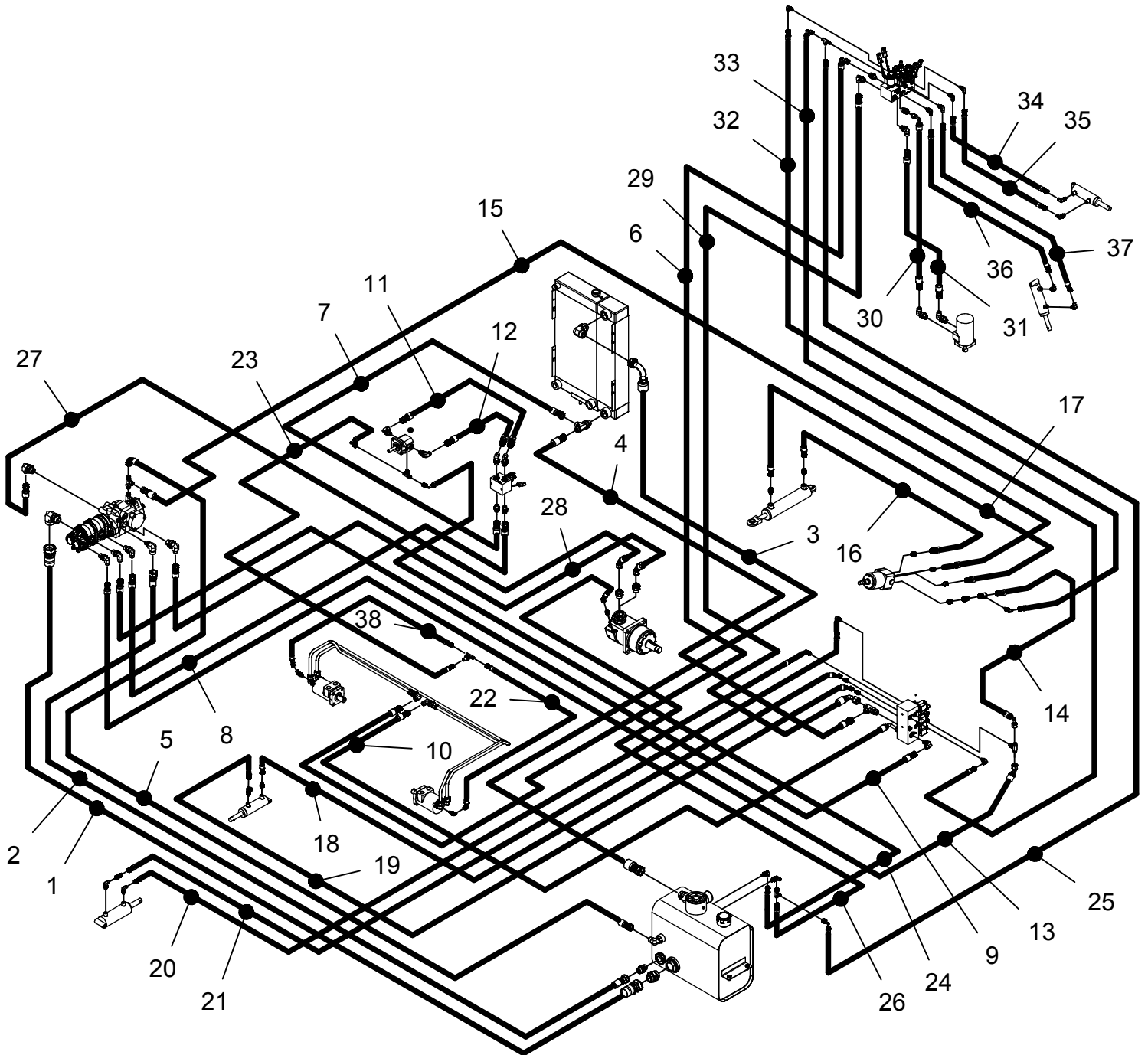

REV A

OPTIONAL SIDE BRUSH
HYDRAULIC HOSE ROUTING
730038

Parts List 730038			
ITEM	PART NUMBER	QTY	DESCRIPTION
1	731051	1	HOSE, 20 STR - 20 STR SUC (RES TO AUX PUMP IN)
2	731052	1	HOSE, 12 STR - 12 STR SUC (RES TO VDP CASE)
3	731053	1	HOSE, 16 STR - 16 90 RET (COOLER UPPER TO RES)
4	731054	1	HOSE, 10 STR - 10 STR RET (VALVE T2 TO COOLER)
5	731055	1	HOSE, 10 STR - 8 90 RET (VDP CASE TO RES)
6	731079	1	HOSE, 8 STR - 8 90 MED (LH MB TO SSB VALVE P2)
7	731057	1	HOSE, 8 STR - 10 STR MED (IMP SOL T TO COOLER)
8	731058	1	HOSE, 8 STR - 8 STR MED (AUX PUMP 1 TO IMP SOL P)
9	731059	1	HOSE, 8 STR - 8 STR MED (AUX PUMP 2 TO VALVE P2)
10	731060	1	HOSE, 8 STR - 8 90 MED (VALVE MB OUT TO MB RIGHT)
11	731061	1	HOSE, 8 STR - 8 90 MED (IMP SOL VF OUT TO IMP LEFT)
12	731062	1	HOSE, 8 STR - 8 90 MED (IMP RIGHT TO IMP SOL VF IN)
13	731063	1	HOSE, 6 STR - 6 90 MED (AUX PUMP 3 TO VALVE P1)
14	731064	1	HOSE, 6 STR - 6 90 MED (VALVE P1 TO STR PRESS)
15	731065	1	HOSE, 6 STR - 8 STR RET (STR TANK TO VDP CASE)
16	731066	1	HOSE, 6 STR - 6 STR MED (STR LEFT TO CYL F)
17	731067	1	HOSE, 6 STR - 6 STR MED (STR RIGHT TO CYL R)
18	731068	1	HOSE, 4 STR - 4 45 MED (VALVE BL A TO SH CYL F)
19	731069	1	HOSE, 4 STR - 4 45 MED (VALVE BL A TO SH CYL R)
20	731070	1	HOSE, 4 STR - 4 STR MED (VALVE SG B TO SQU CYL F)
21	731071	1	HOSE, 4 STR - 4 STR MED (VALVE SG A TO SQU CYL R)
22	731072	1	HOSE, 4 STR - 4 45 MED (RH MB CASE TO SCRUB HEAD TEE)
23	731073	1	HOSE, 4 STR - 4 90 MED (SCRUB HD TO IMP CASE)
24	731074	1	HOSE, 4 STR - 4 90 MED (IMP CASE TO RES)
25	731075	1	HOSE, 4 STR - 4 90 MED (SSB VALVE T1 TO RES)
26	731076	1	HOSE, 4 STR - 4 45 MED (WHEEL DRIVE CASE TO RES)
27	731077	1	HOSE, 8 STR - 8 45 SPCL (VDP L TO WHEEL DRIVE R)
28	731078	1	HOSE, 8 STR - 8 45 SPCL (VDP R TO WHEEL DRIVE F)
29	731081	1	HOSE, 8 45 - 10 90 MED (SSB VALVE T2 TO VALVE T2)
30	731082	1	HOSE, 8 STR - 8 90 MED (SSB VALVE SB OUT TO SB R)
31	731083	1	HOSE, 8-STR - 8 STR MED (SSB VALVE SB IN TO SB F)
32	731084	1	HOSE, 4-STR - 4 STR MED (STR TEE TO SSB VALVE P1)
33	731085	1	HOSE, 4 STR - 4 90 MED (VALVE T1 TO SSB VALVE T1)
34	731089	1	HOSE, 4 STR - 4 STR MED (SSB VALVE SBE A TO EXT CYL L)
35	731087	1	HOSE, 4 STR - 4 STR MED (SSB VALVE SBE B TO EXT CYL R)
36	731088	1	HOSE, 4 STR - 4 STR MED (SSB VALVE SBL A TO LIFT CYL U)
37	731089	1	HOSE, 4 STR - 4 STR MED (SSB VALVE SBL B TO LIFT CYL L)
38	731168	1	HOSE, 4 STR - 4 45 MED (LH MB CASE TO SCRUB HEAD TEE)

REV A

REV	ECN #	DATE	DESCRIPTION OF CHANGE-IS (WAS)	BY:
☆	X	4-2-2014	RELEASED FOR PRODUCTION	CMK

SSB-HFP

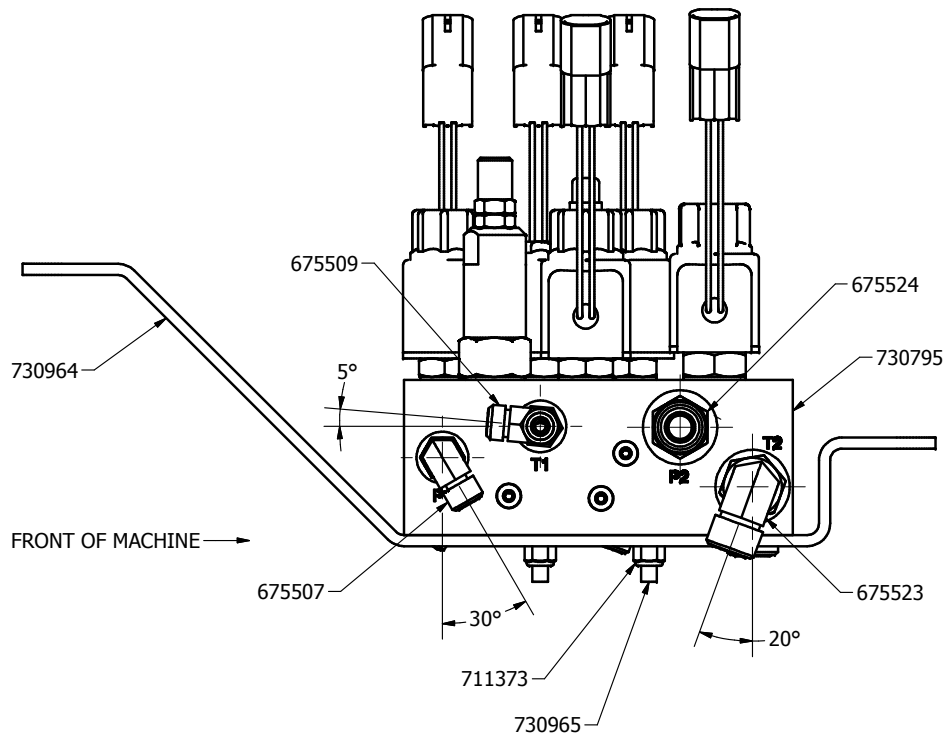

(OPERATORS) RIGHT SIDE VIEW

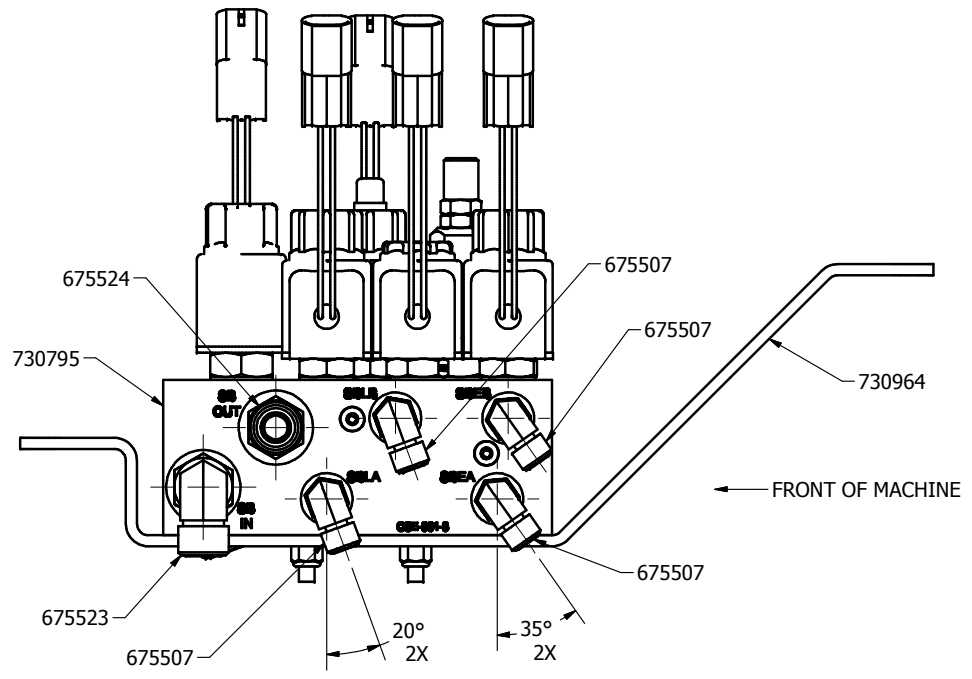

(OPERATORS) LEFT SIDE VIEW

CONFIDENTIAL

THIS DRAWING AND ALL INFORMATION CONTAINED THEREIN ARE THE EXCLUSIVE PROPERTY OF MINUTEMAN INTERNATIONAL, INC. THIS DRAWING IS NOT TO BE COPIED OR OTHERWISE REPRODUCED WITHOUT EXPRESSED WRITTEN PERMISSION OF MINUTEMAN INTERNATIONAL, INC. IN ADDITION, THIS DRAWING MUST BE RETURNED UPON REQUEST. FURTHER, ALL INFORMATION CONTAINED HEREIN MUST BE MAINTAINED CONFIDENTIAL.

SOURCE:				175 Anderson Street Aberdeen, NC 28315	
PN. MATL:				PHONE (910) 944-2105 FAX (910) 944-7409	
FINISH:		CAD BY: KNOWLTON		DATE: 4/2/2014	
UNSPECIFIED TOLERANCES .X .1 ANGULAR: .XX .03 X .1 .XXX 0.10 X .5		DESCRIPTION SSB HYDRAULIC FITTING POSITIONS			
DES. ENG: KNOWLTON		PART NO. SSB-HFP		REV LEV	SHT NO. 1
ENG. REL:					

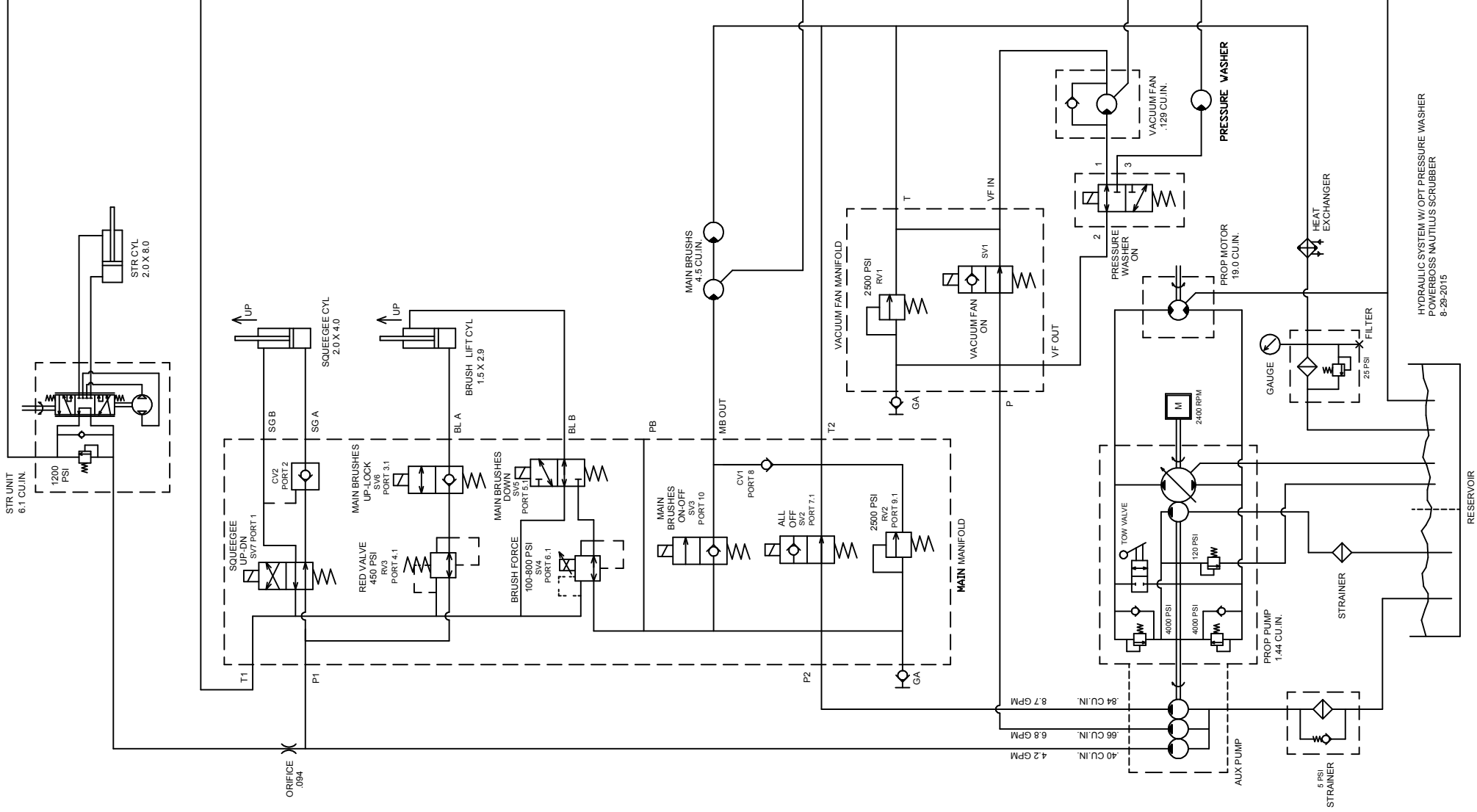

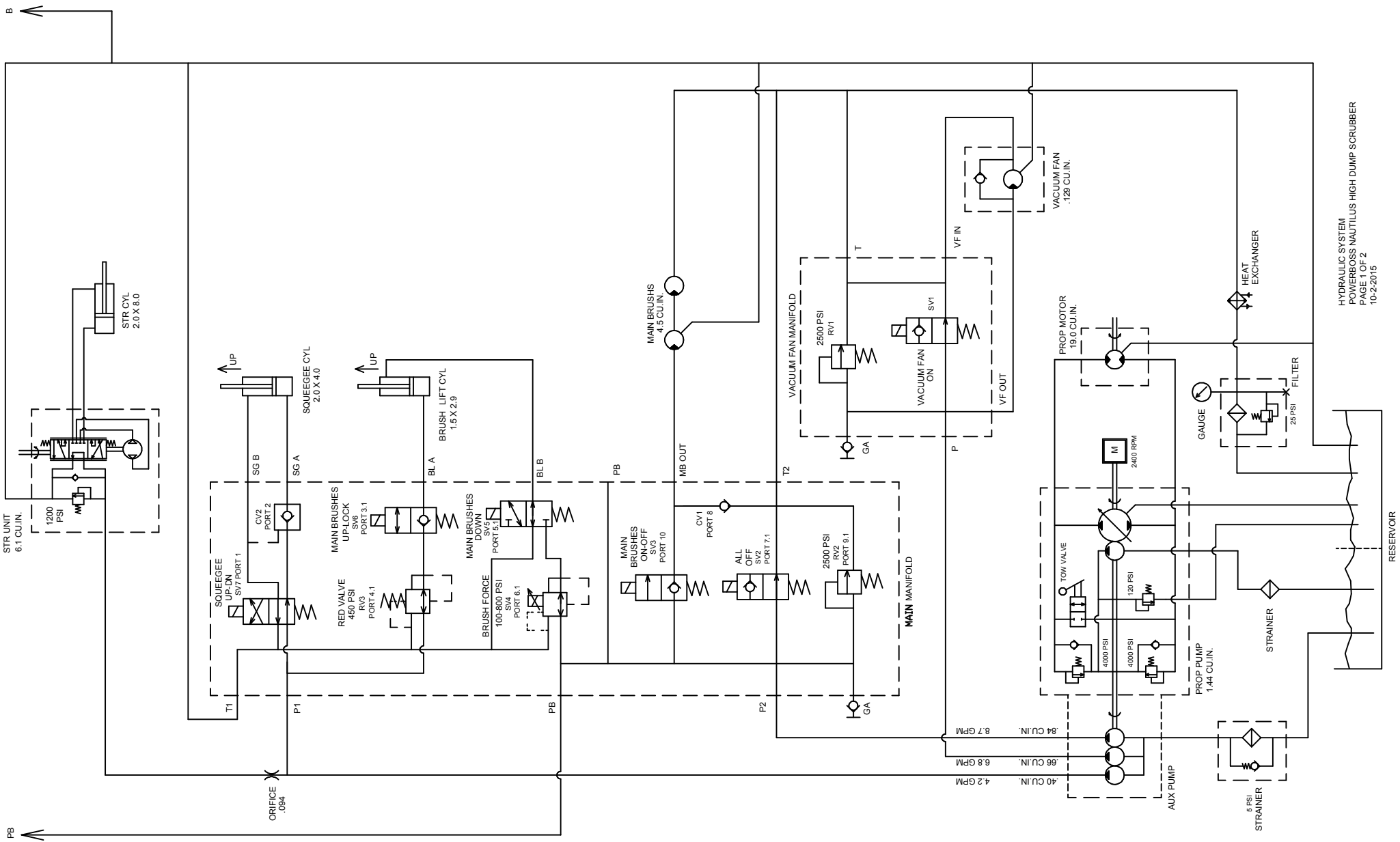

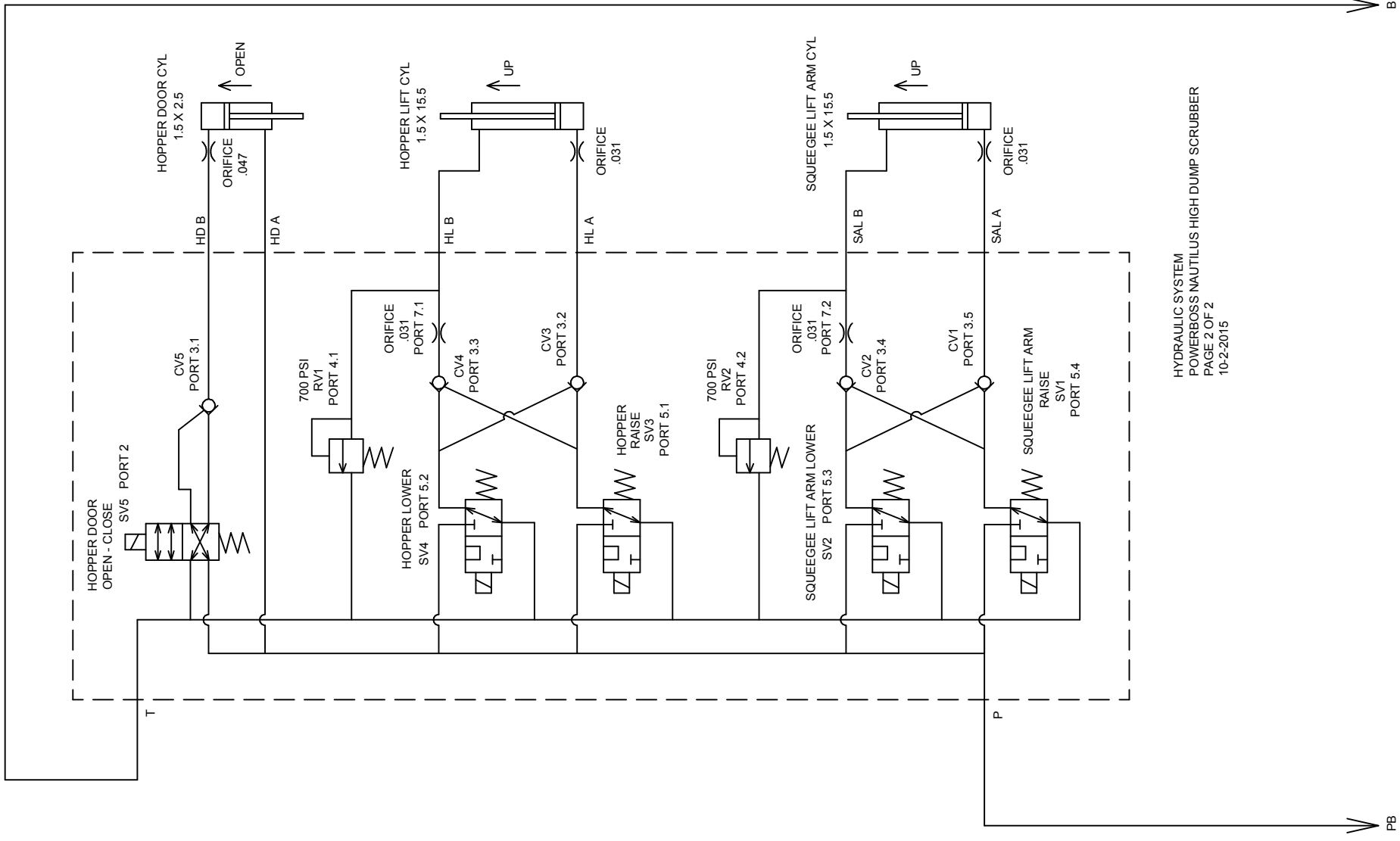

HYDRAULIC SYSTEM
 POWERBOSS NAUTILUS HIGH DUMP SCRUBBER
 PAGE 2 OF 2
 10-2-2015

B

PB

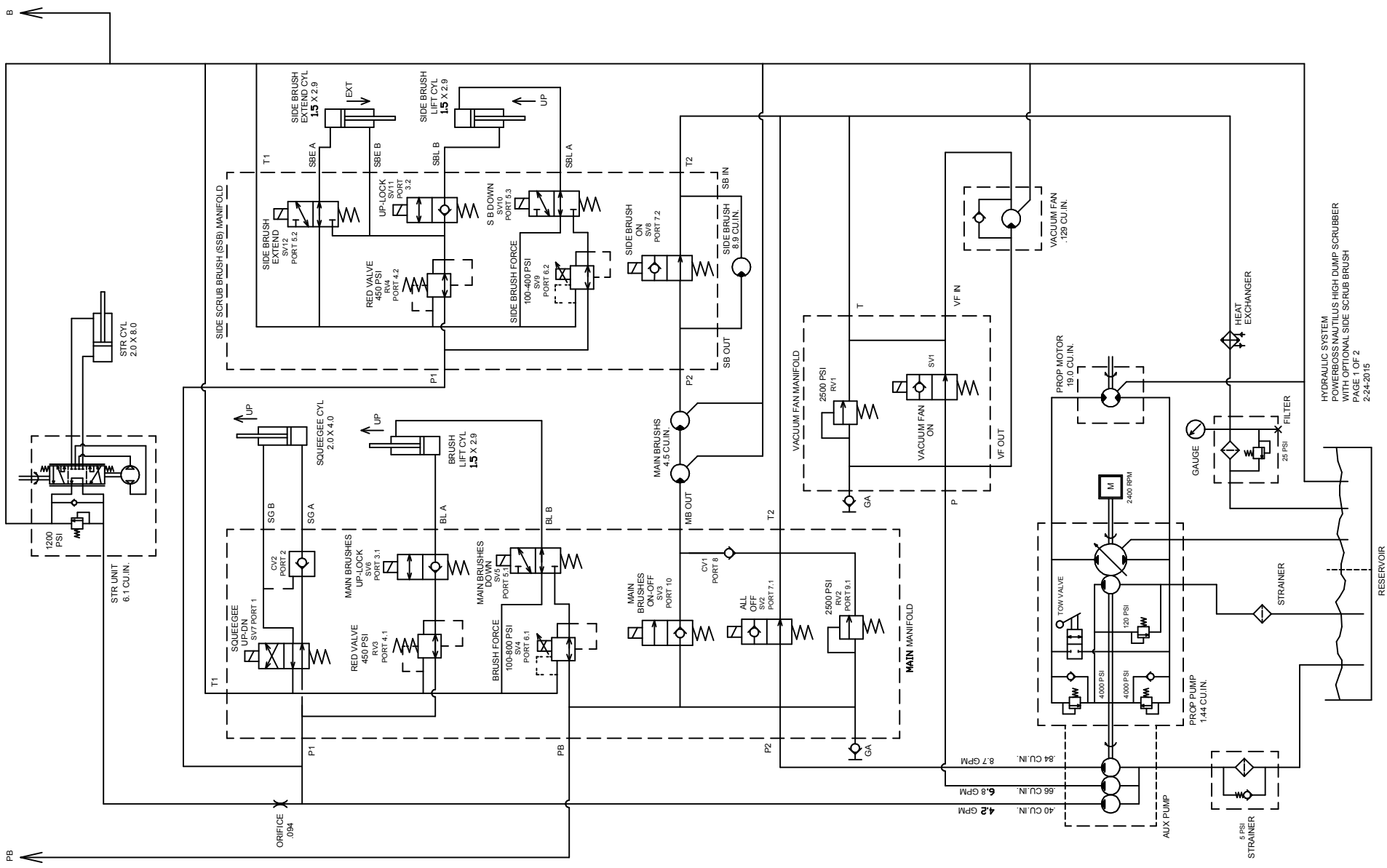

HYDRAULIC SYSTEM
 POWER BRUSH PLUS HIGH DUMP SCRUBBER
 WITH OPTIONAL SIDE SCRUB BRUSH
 PAGE 1 OF 2
 2-24-2015

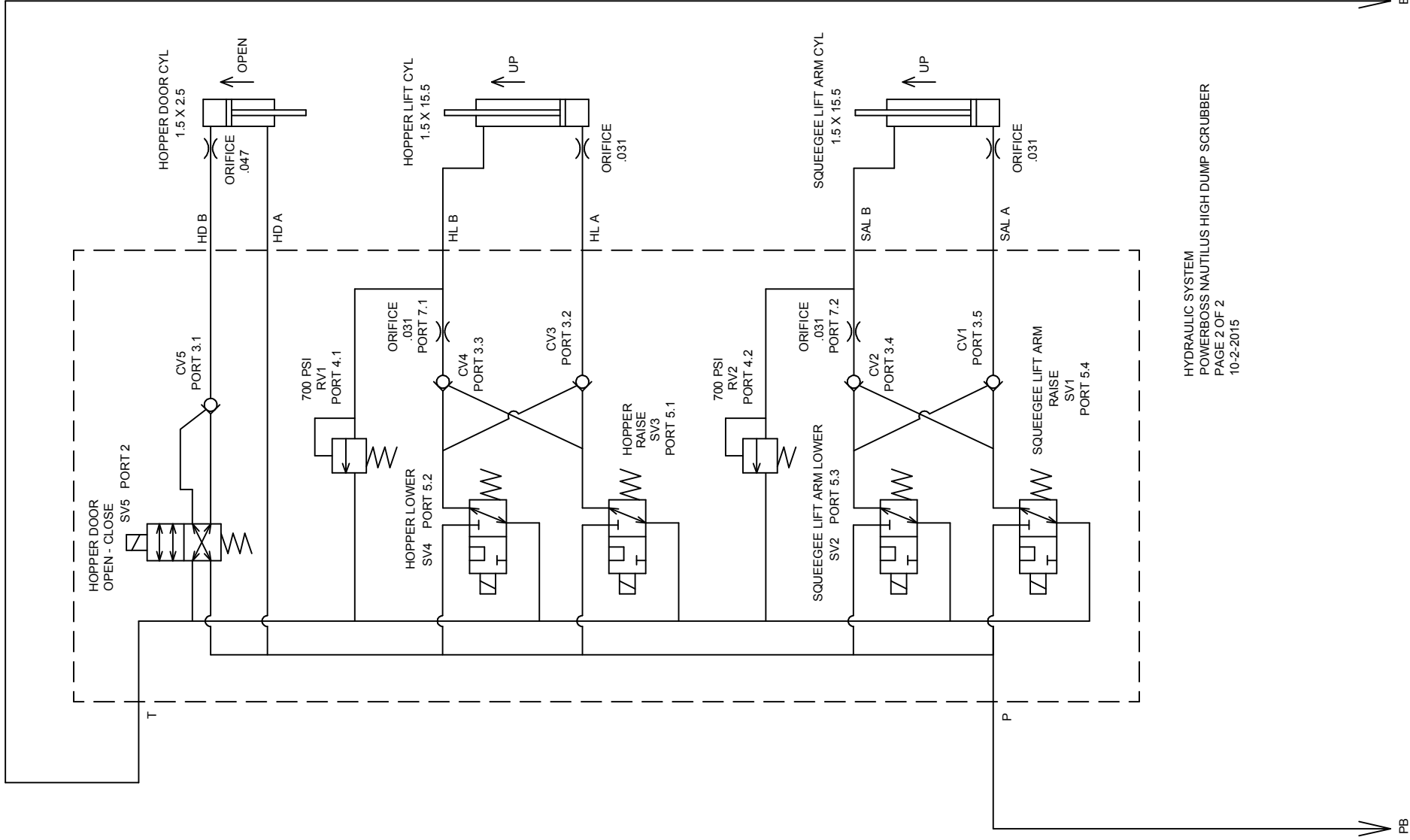

HYDRAULIC SYSTEM
 POWERBOSS NAUTILUS HIGH DUMP SCRUBBER
 PAGE 2 OF 2
 10-2-2015

PB

B

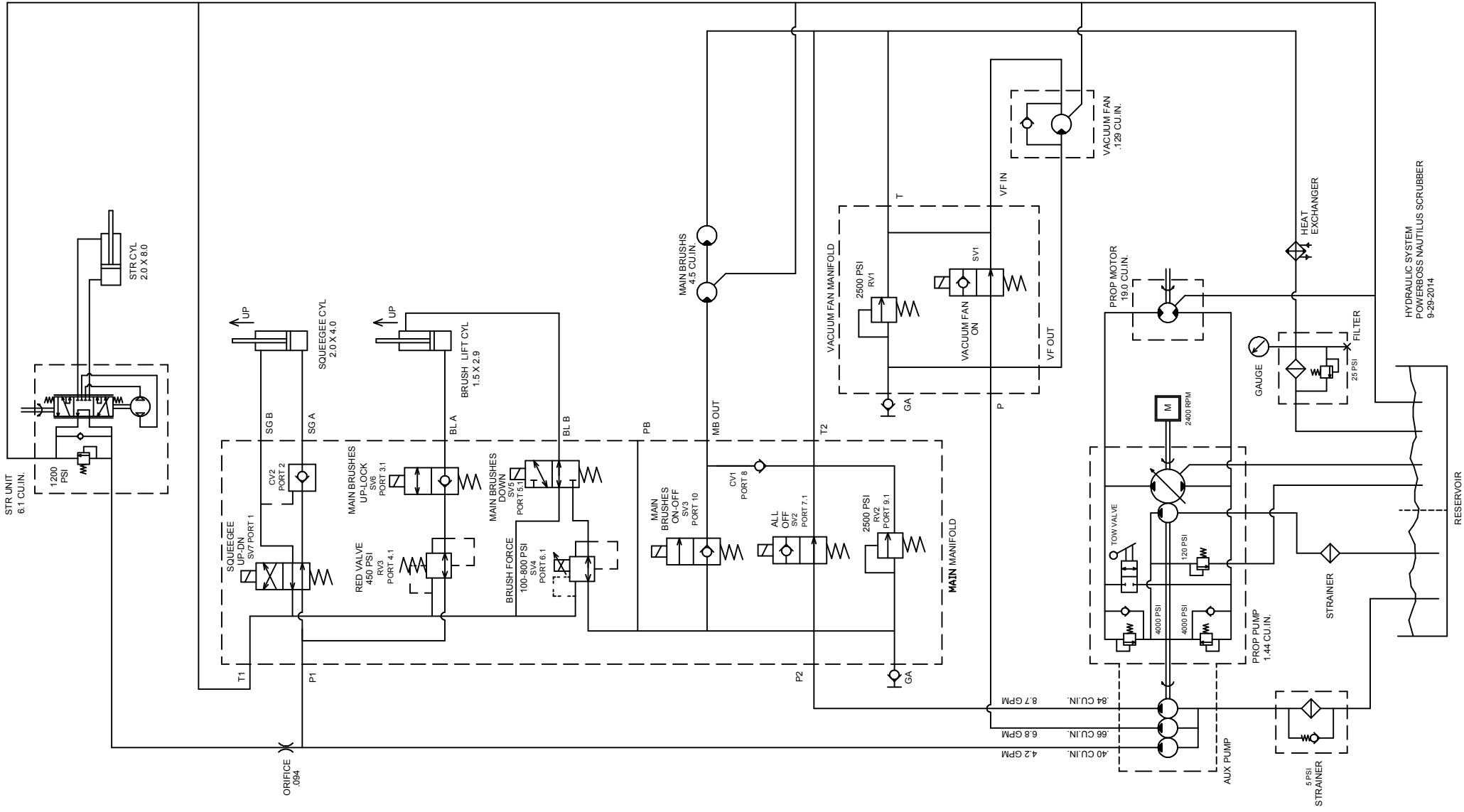

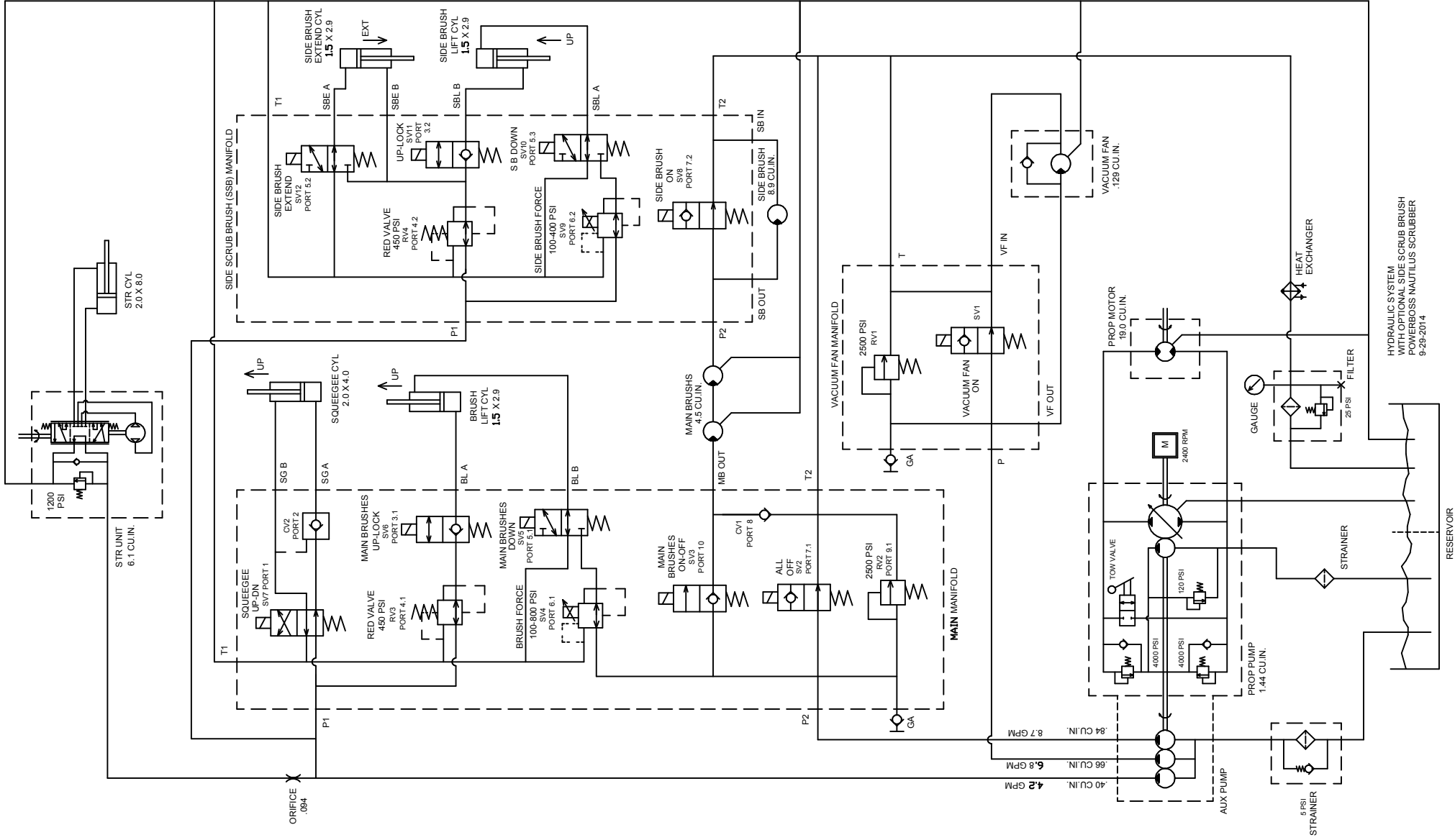

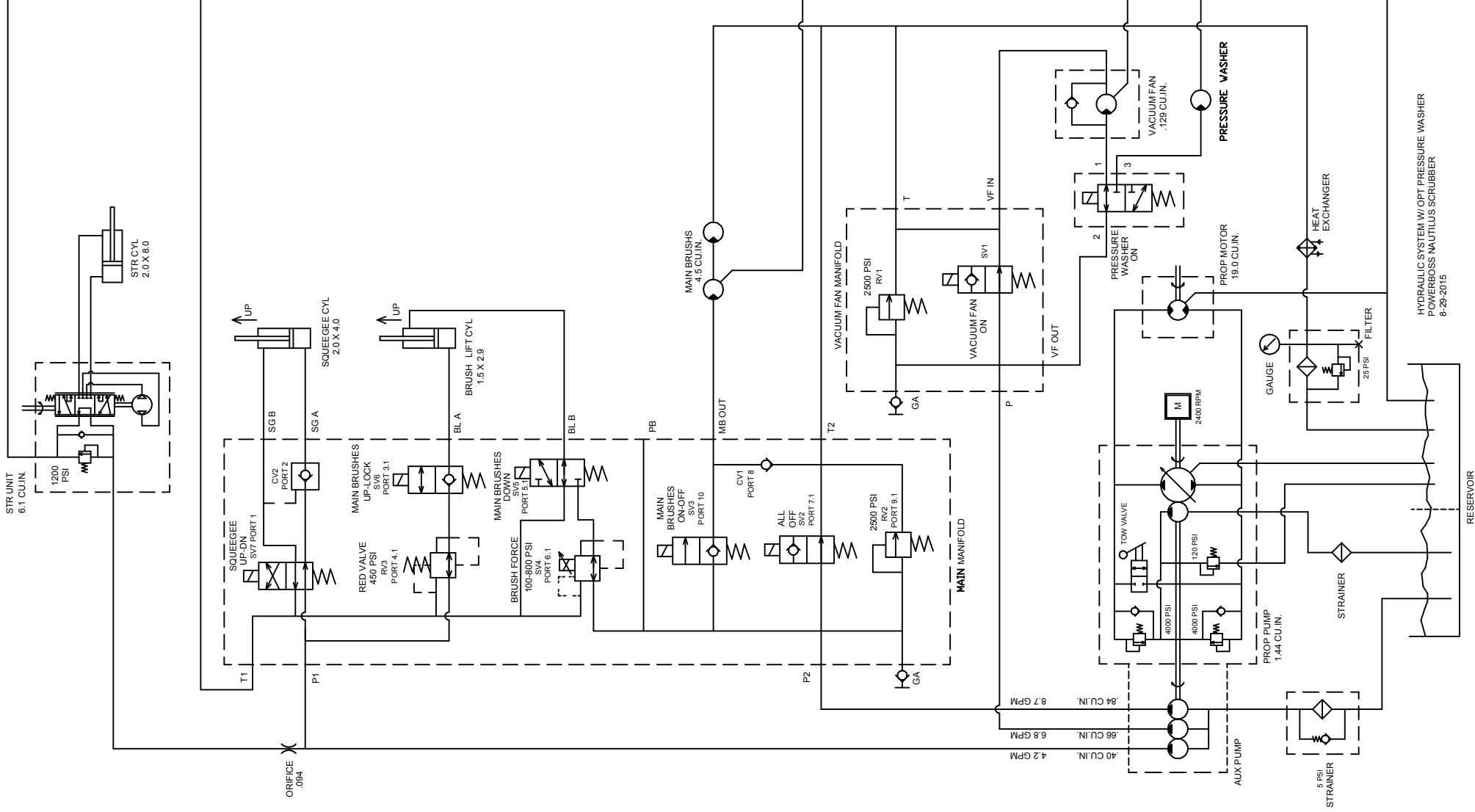

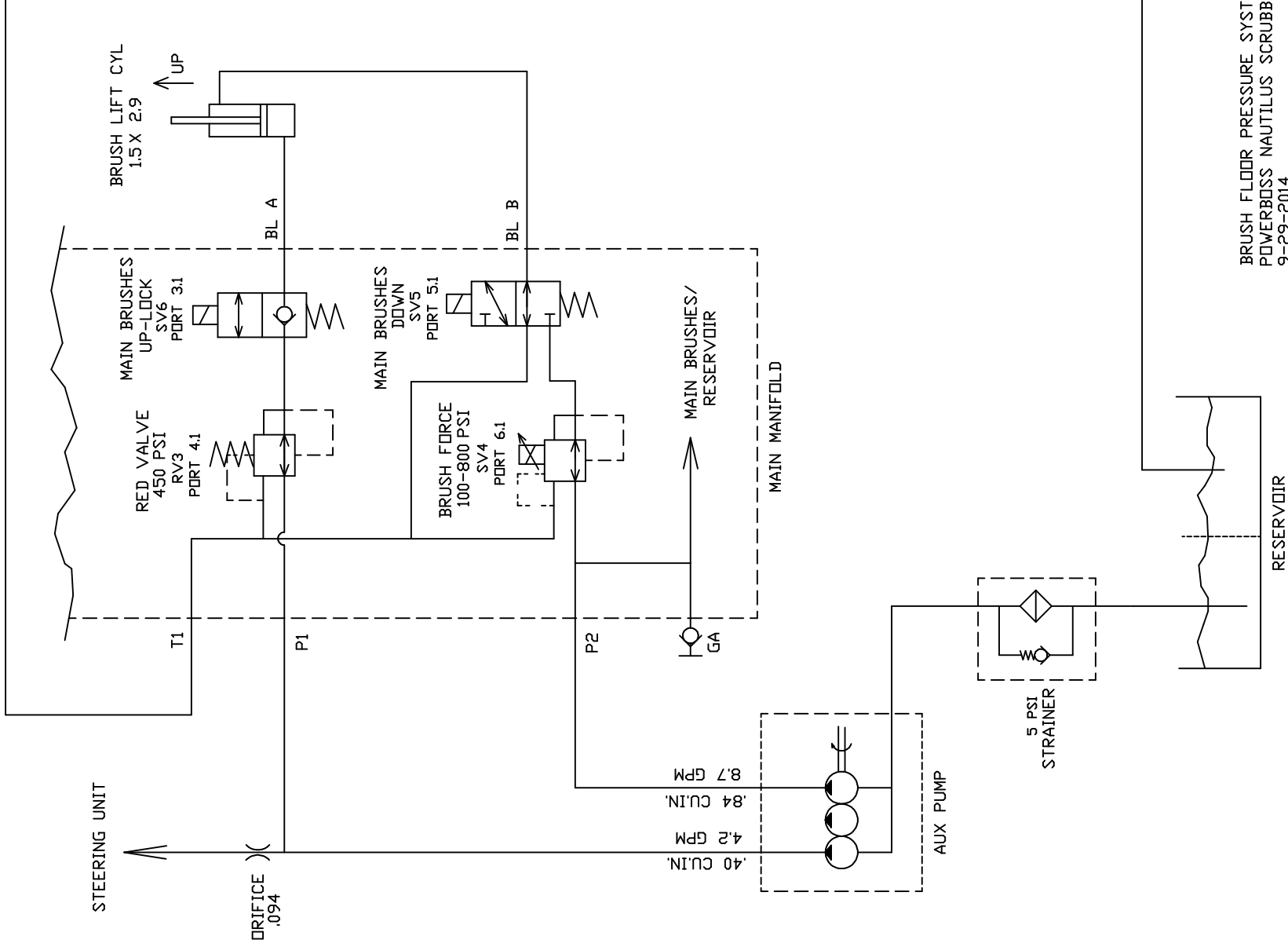

BRUSH FLOOR PRESSURE SYSTEM
POWERBOSS NAUTILUS SCRUBBER
9-29-2014

TYPICAL SCHEMATIC COMPONENT SYMBOLS

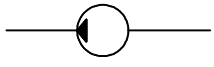

PUMP

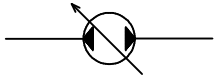

VARIABLE DISPLACEMENT
(PROPULSION) PUMP



MOTOR



BI-DIRECTIONAL
(PROPULSION) MOTOR

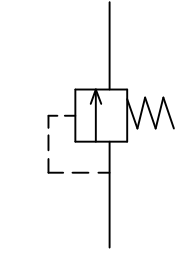

PRESSURE RELIEF
VALVE

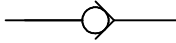

CHECK VALVE



ORIFICE

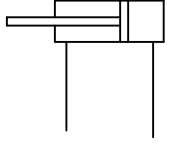

CYLINDER

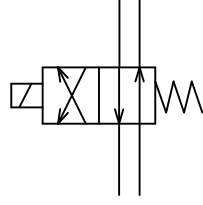
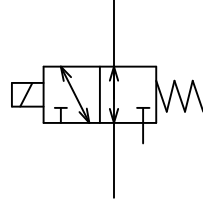
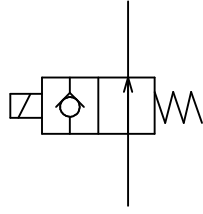

DIRECTIONAL CONTROL VALVES

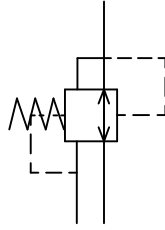

PRESSURE REDUCTION
VALVE

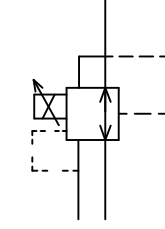

PROPORTIONAL PRESSURE
REDUCTION VALVE

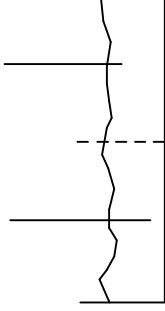

RESERVOIR

TO BRUSH FLOOR PRESSURE SYSTEM

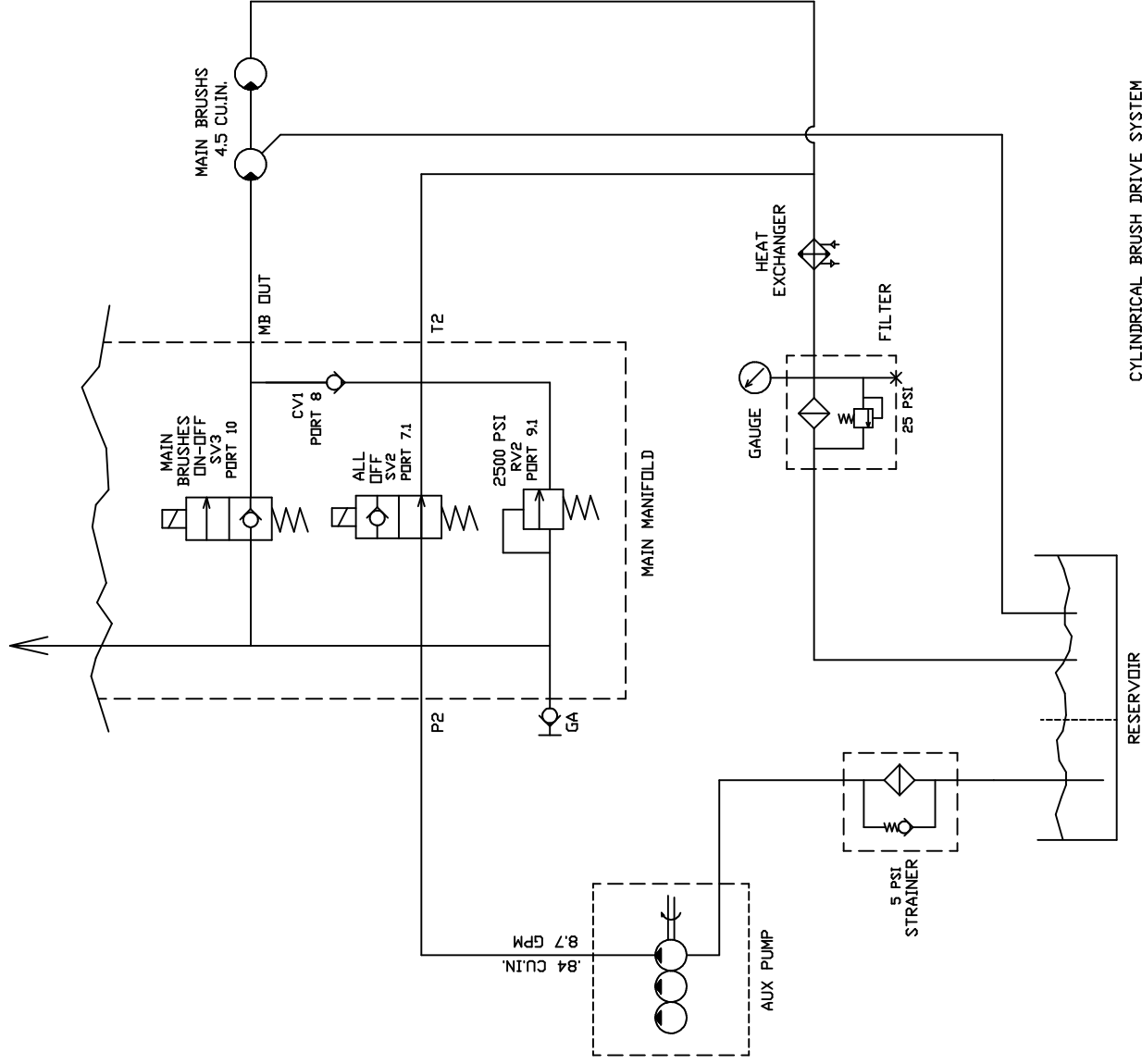

CYLINDRICAL BRUSH DRIVE SYSTEM
POWERBOSS NAUTILUS SCRUBBER
9-29-2014

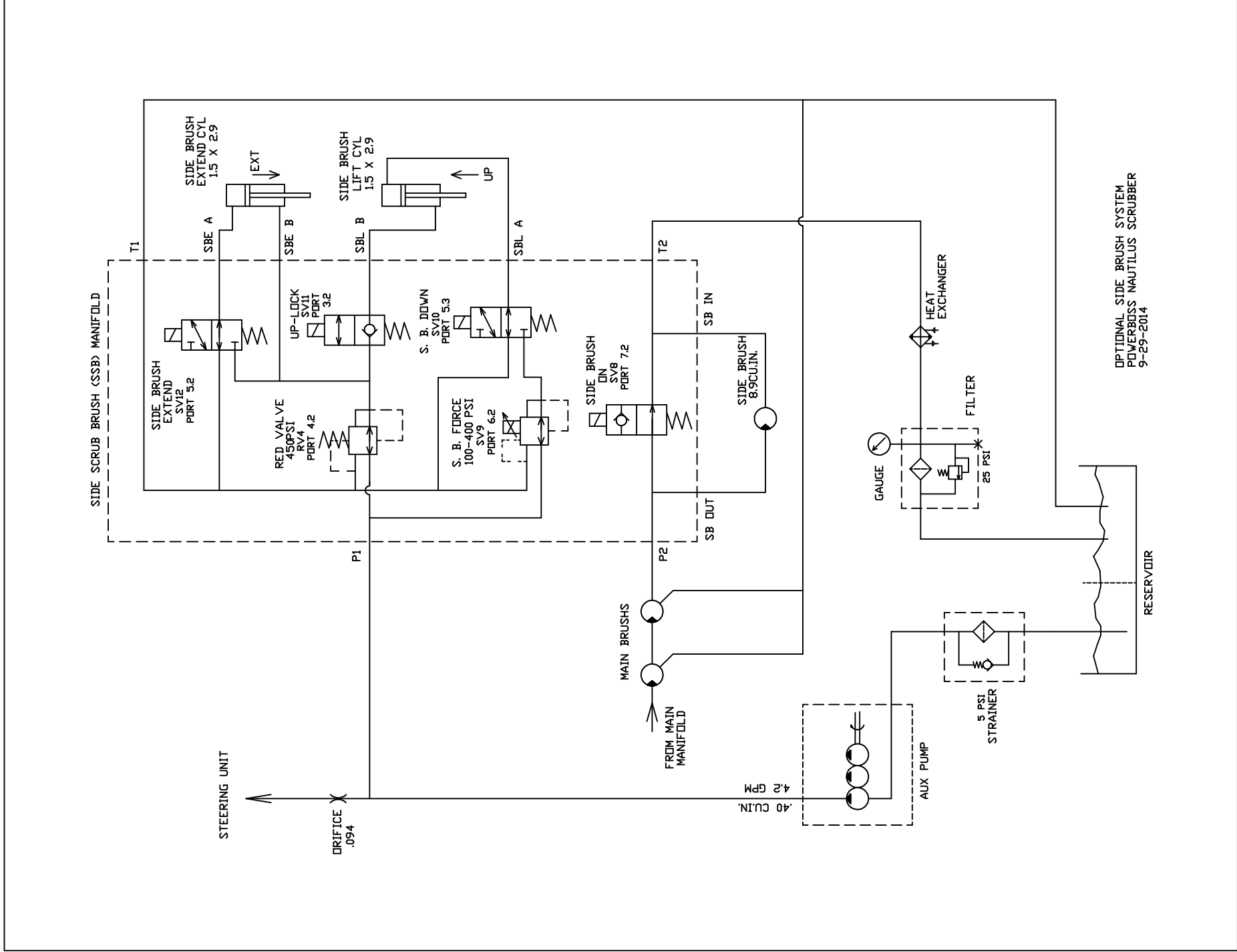

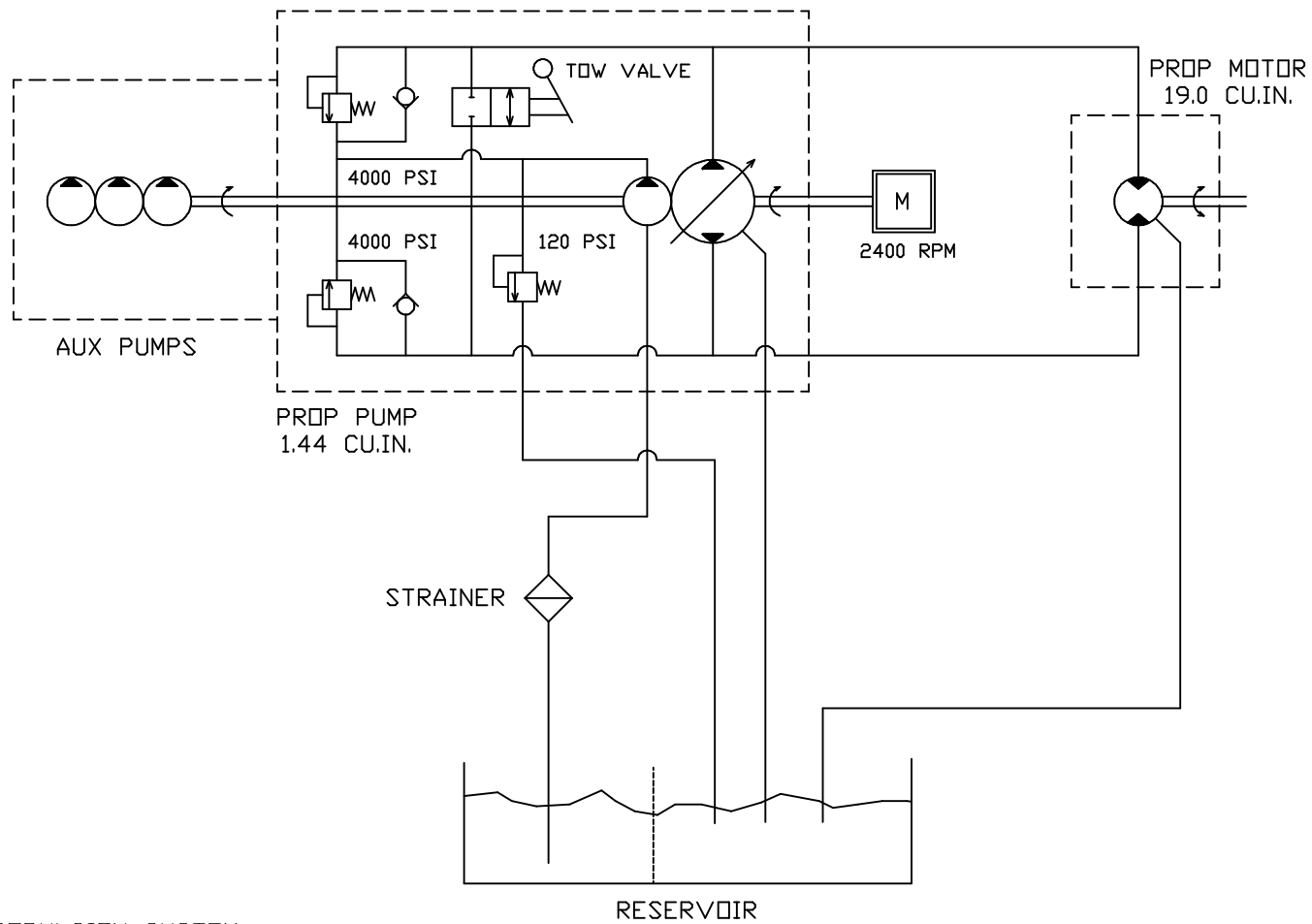

PROPULSION SYSTEM
 POWERBOSS NAUTILUS SCRUBBER
 9-29-2014

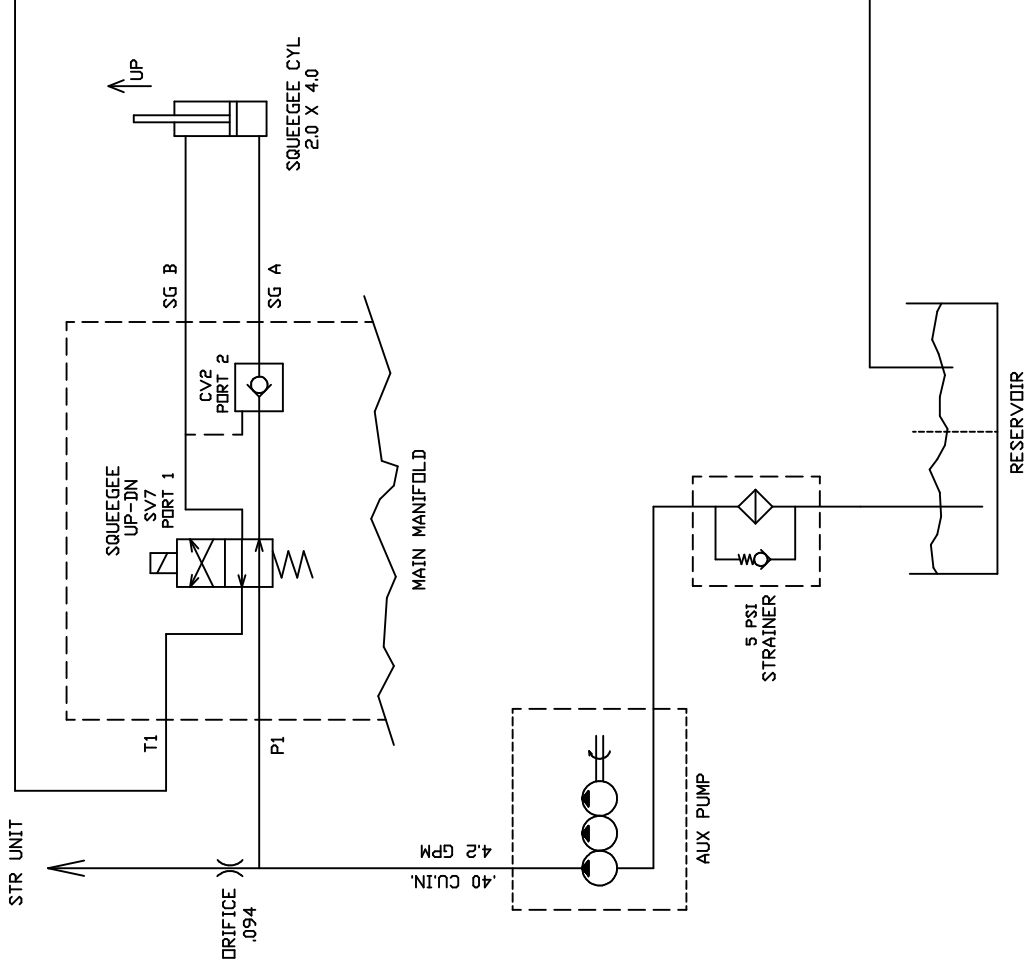

SQUEEGEE LIFT SYSTEM
 POWERBOSS NAUTILUS SCRUBBER
 9-29-2014

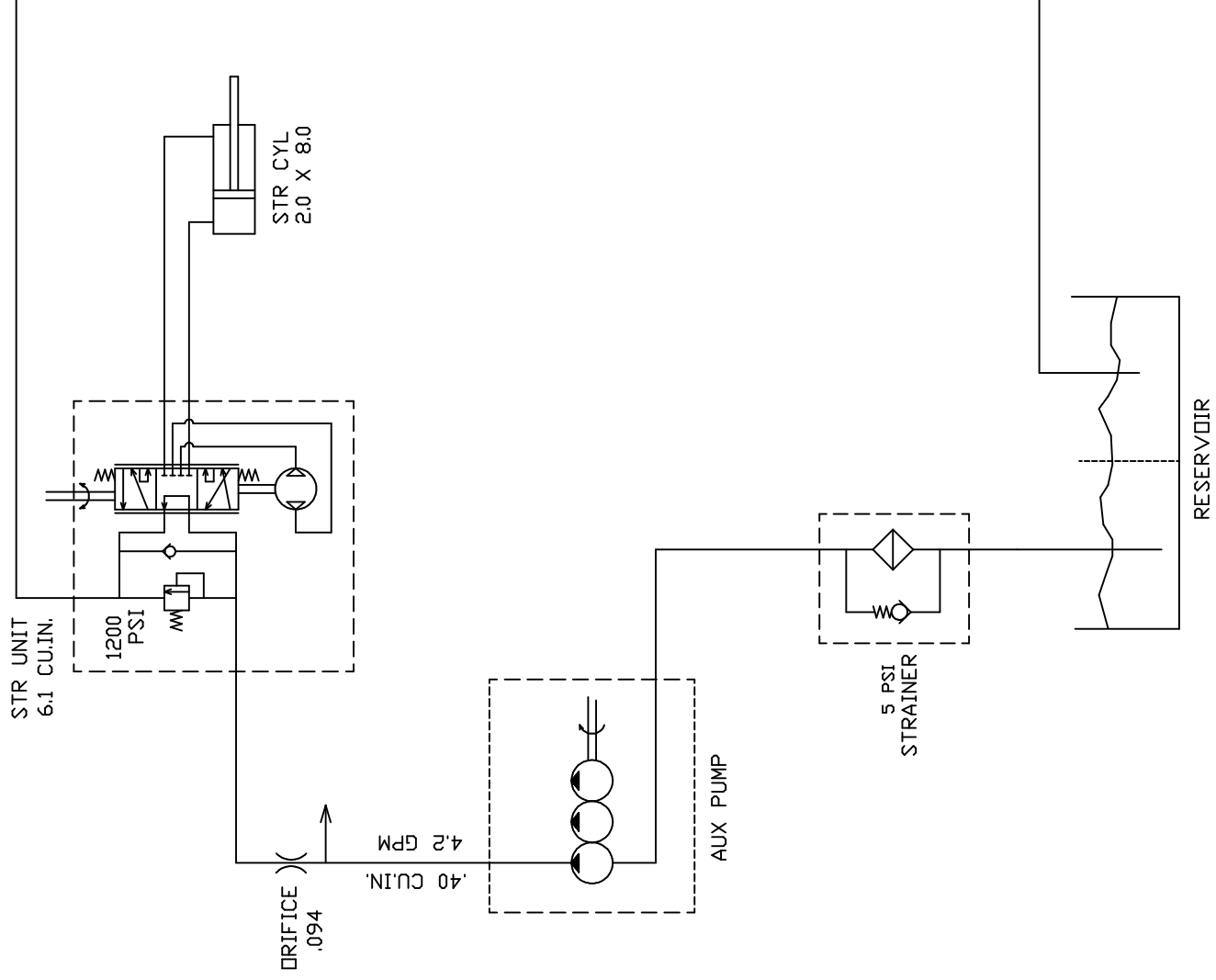

STEERING SYSTEM
 POWERBOSS NAUTILUS SCRUBBER
 9-29-2014

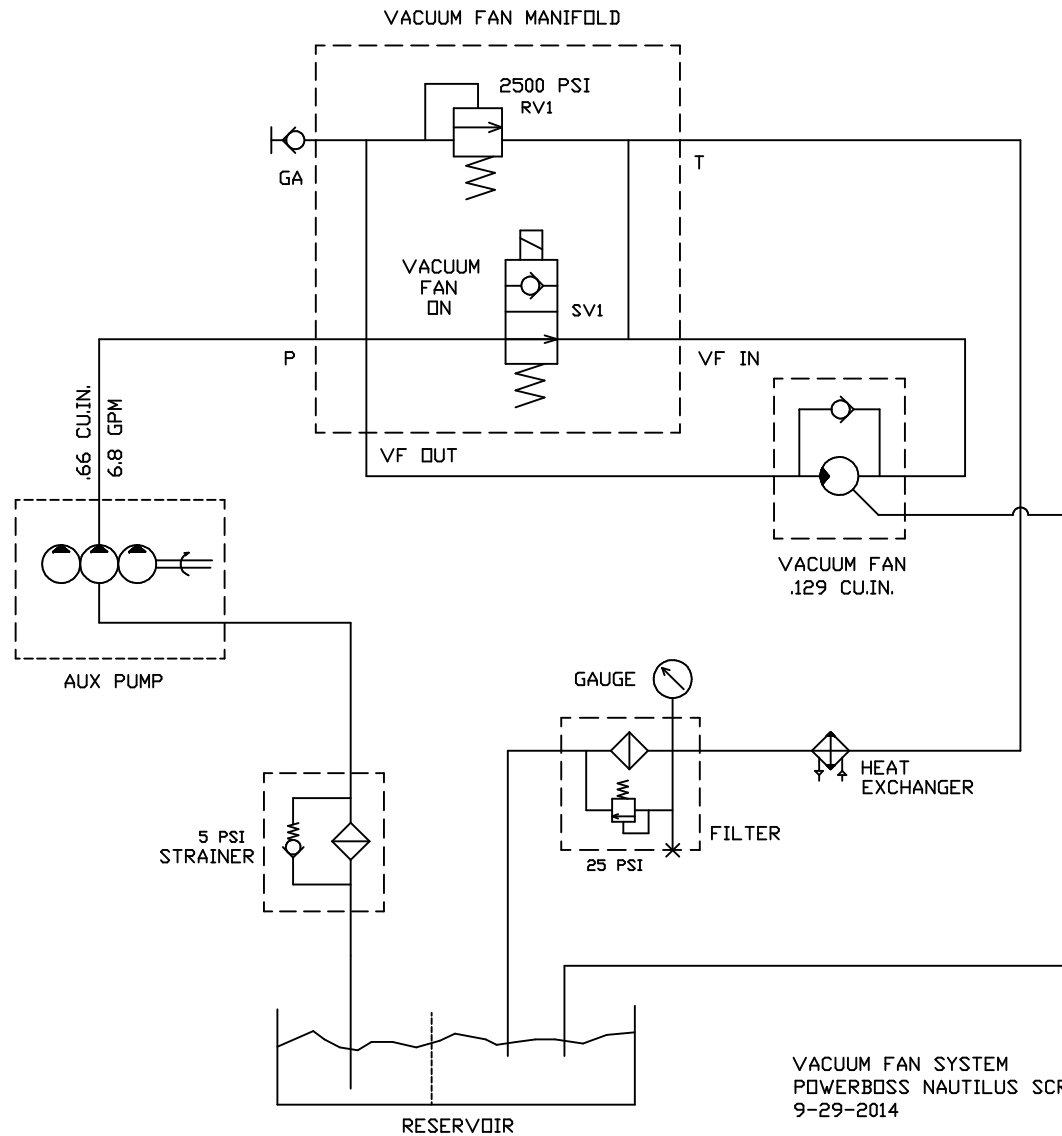

VACUUM FAN SYSTEM
 POWERBOSS NAUTILUS SCRUBBER
 9-29-2014

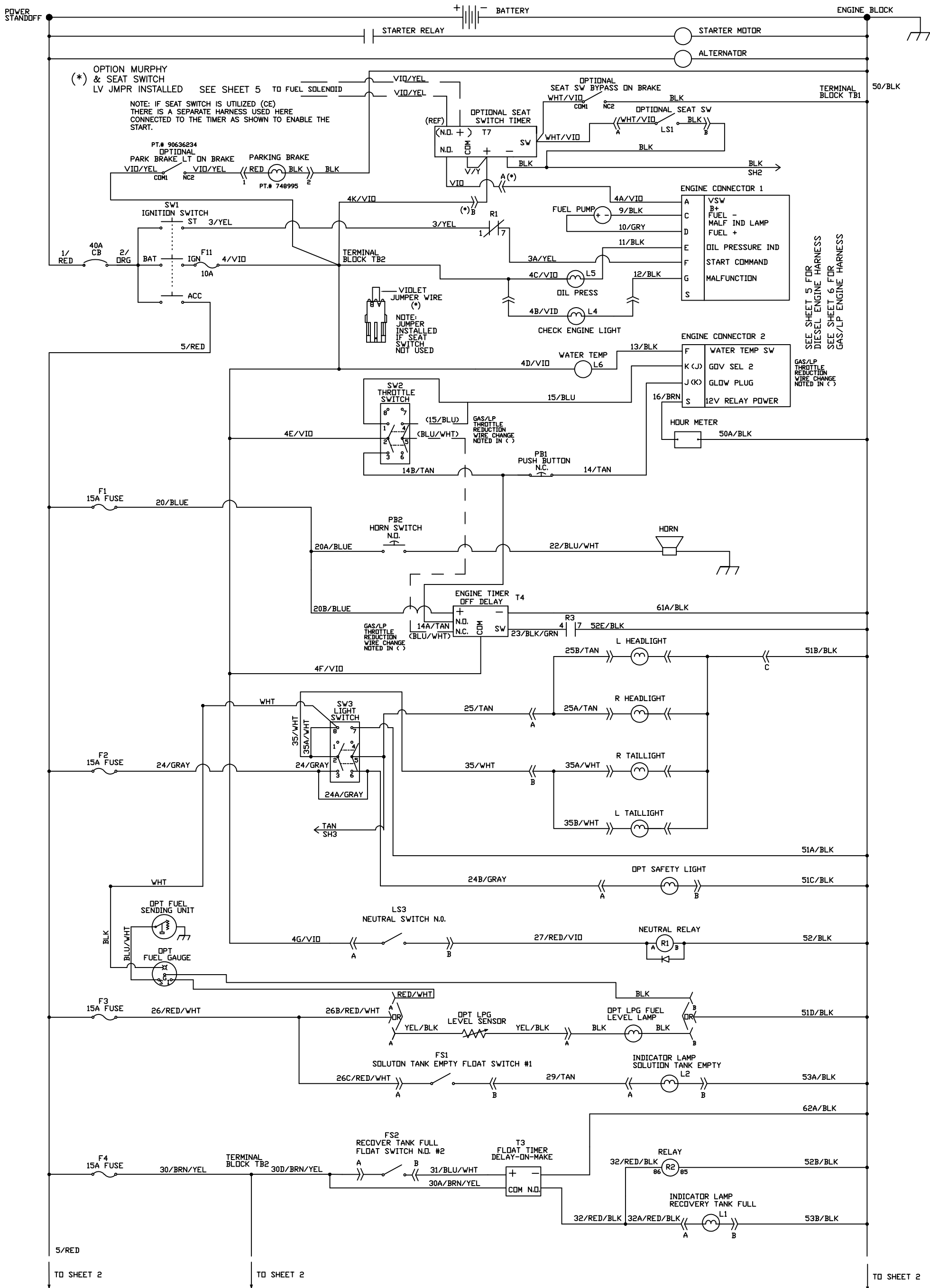

SEE SHEET 5 FOR DIESEL ENGINE HARNESS
SEE SHEET 6 FOR GAS/LP ENGINE HARNESS

GAS/LP THROTTLE REDUCTION WIRE CHANGE NOTED IN ()

CONFIDENTIAL
THIS DRAWING AND ALL INFORMATION CONTAINED THEREIN ARE THE EXCLUSIVE PROPERTY OF MINUTEMAN INTERNATIONAL, INC. THIS DRAWING IS NOT TO BE COPIED OR OTHERWISE REPRODUCED WITHOUT EXPRESSED WRITTEN PERMISSION OF MINUTEMAN INTERNATIONAL, INC. IN ADDITION, THIS DRAWING MUST BE RETURNED UPON REQUEST. FURTHER, ALL INFORMATION CONTAINED HEREIN MUST BE MAINTAINED CONFIDENTIAL.

TITLE NAUTILUS ELECTRICAL SCHEMATIC SCALE NTS
MATERIAL N/A FINISH N/A

TOLERANCES (UNLESS OTHERWISE SPECIFIED) REMOVE BURRS AND BREAK SHARP EDGES .005/.020
0-1" ± 1/16 .00 ± .005 SIZE DRAWN BY KHH DATE 08/03/15
>1-12" ± 1/4" .00 ± .010 B CHECKED BY JWP DATE 08/03/15
<12" ± 1/2" ANGLES ± 30'

MINUTEMAN 14N845 U.S. ROUTE 20 PINGREE GROVE, IL 60140 P.N. 748992-1 REV J
SHEET 1 OF 6

REV	E.C.N.	DATE	CHANGE	BY	CHK BY
J	151969	02/02/22	ADD CONSTANT SOLUTION FLOW OPTIONS CHANGE F5 FUSE TO 20 AMPS, DELETE 106A	KHH	KHH
H	151293	04/09/20	UPDATED MURPHY SWITCH	KHH	KHH
G	150567	02/06/19	ADDED SIDE BROOM MIST OPTION	KHH	KHH
F	150447	10/18/18	ADD BRAKE LIGHTS	KHH	KHH

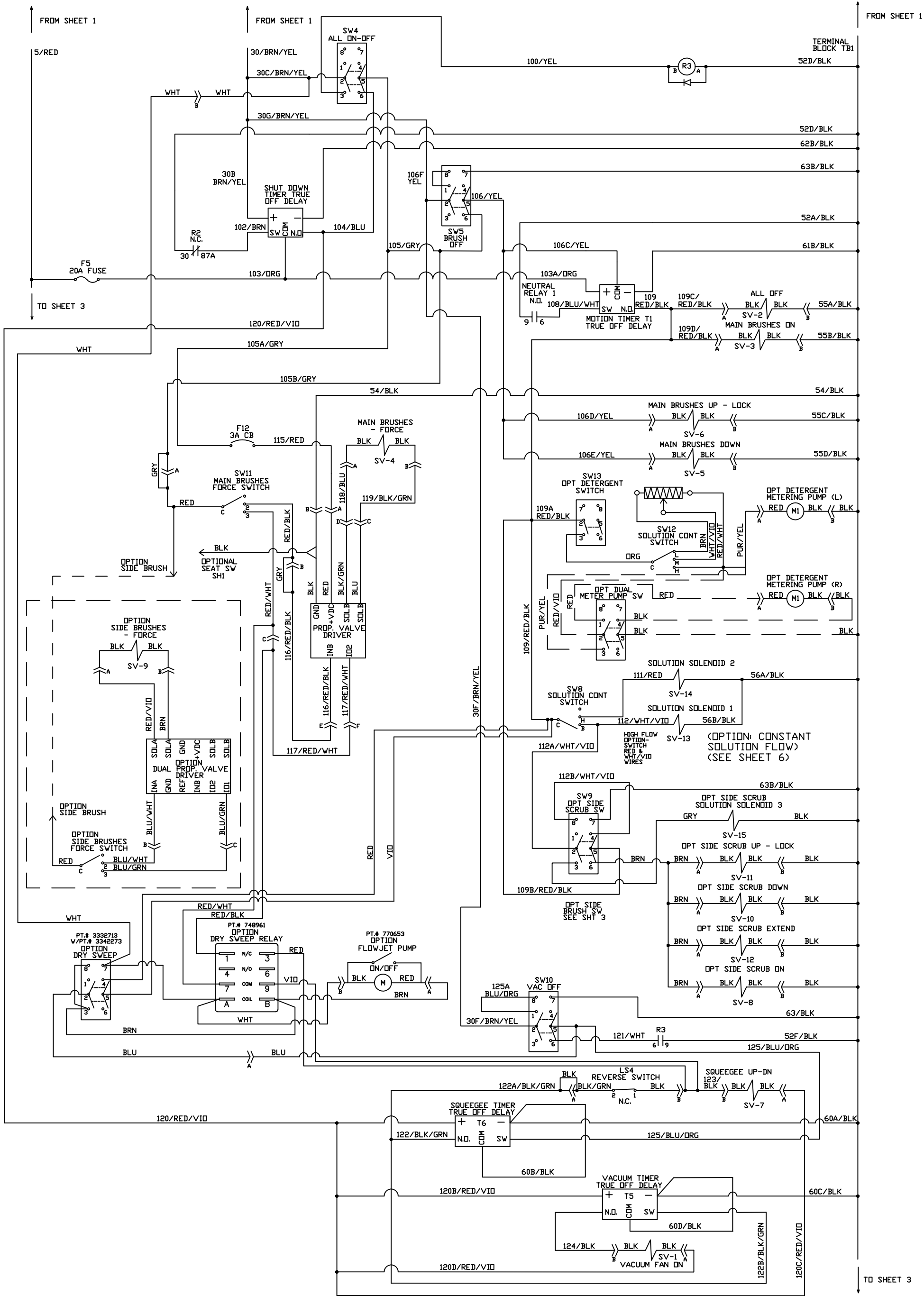

CONFIDENTIAL

THIS DRAWING AND ALL INFORMATION CONTAINED THEREIN ARE THE EXCLUSIVE PROPERTY OF MINUTEMAN INTERNATIONAL, INC. THIS DRAWING IS NOT TO BE COPIED OR OTHERWISE REPRODUCED WITHOUT EXPRESSED WRITTEN PERMISSION OF MINUTEMAN INTERNATIONAL, INC. IN ADDITION, THIS DRAWING MUST BE RETURNED UPON REQUEST. FURTHER, ALL INFORMATION CONTAINED HEREIN MUST BE MAINTAINED CONFIDENTIAL.

TITLE		NAUTILUS ELECTRICAL SCHEMATIC		SCALE		NTS	
MATERIAL		N/A		FINISH		N/A	
TOLERANCES (UNLESS OTHERWISE SPECIFIED)		REMOVE BURRS AND BREAK SHARP EDGES .005/.020		SIZE		DRAWN BY KHH	
0-1" ± 1/16		.000 ± .005		B		CHECKED BY JWP	
>1-12" ± 1/4"		.00 ± .010				DATE 08/03/15	
<12" ± 1/2"		ANGLES ± 30'				DATE 08/03/15	
REV		E.C.N.		DATE		CHANGE	
BY		CHK		BY		BY	

14N845 U.S. ROUTE 20
 PINGREE GROVE, IL 60140
P.N. 748992-1
 SHEET 2 OF 6

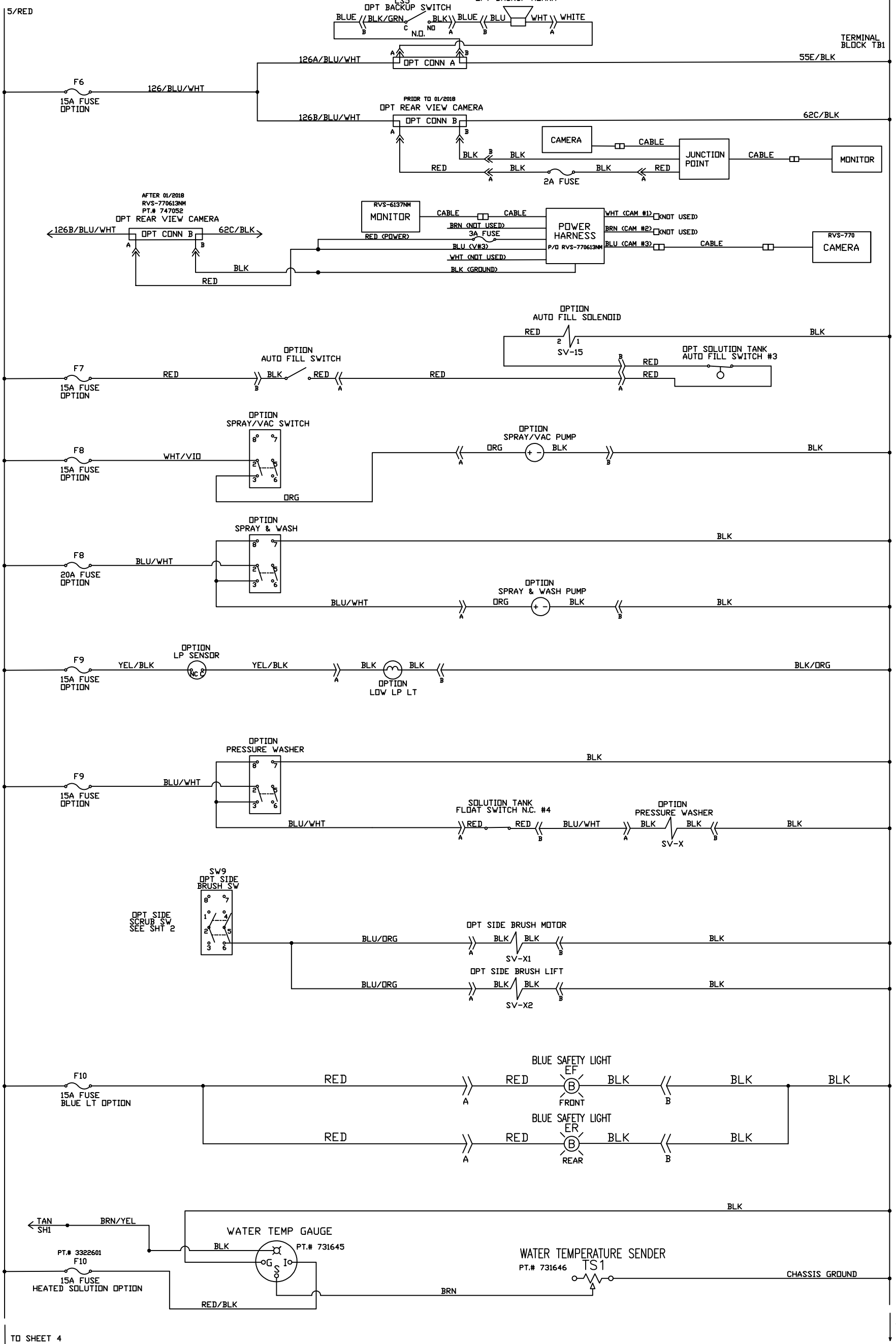

CONFIDENTIAL									
THIS DRAWING AND ALL INFORMATION CONTAINED THEREIN ARE THE EXCLUSIVE PROPERTY OF MINUTEMAN INTERNATIONAL, INC. THIS DRAWING IS NOT TO BE COPIED OR OTHERWISE REPRODUCED WITHOUT EXPRESSED WRITTEN PERMISSION OF MINUTEMAN INTERNATIONAL, INC. IN ADDITION, THIS DRAWING MUST BE RETURNED UPON REQUEST. FURTHER, ALL INFORMATION CONTAINED HEREIN MUST BE MAINTAINED CONFIDENTIAL.									
TITLE NAUTILUS ELECTRICAL SCHEMATIC								SCALE NTS	
MATERIAL N/A					FINISH N/A				
TOLERANCES (UNLESS OTHERWISE SPECIFIED)					REMOVE BURRS AND BREAK SHARP EDGES .005/.020				
0-1" ± 1/16		.000 ± .005		SIZE B		DRAWN BY KHH		DATE 08/03/15	
>1-12" ± 1/4"		.00 ± .010		CHECKED BY JWP		DATE 08/03/15			
<12" ± 1/2"		ANGLES ± 30'							
				14N845 U.S. ROUTE 20 PINGREE GROVE, IL 60140		P.N. 748992-1		REV J	
SHEET 3 OF 6									

REV	E.C.N.	DATE	CHANGE	BY	CHK BY
J	151969	02/02/22	ADD CONSTANT SOLUTION FLOW OPTIONS CHANGE F5 FUSE TO 20 AMPS, DELETE 106A	KHH	KHH
H	151293	04/09/20	UPDATED MURPHY SWITCH	KHH	KHH
G	150567	02/06/19	ADDED SIDE BROOM MIST OPTION	KHH	KHH
F	150447	10/18/18	ADD BRAKE LIGHTS	KHH	KHH

NAUTILUS HD

5/RED

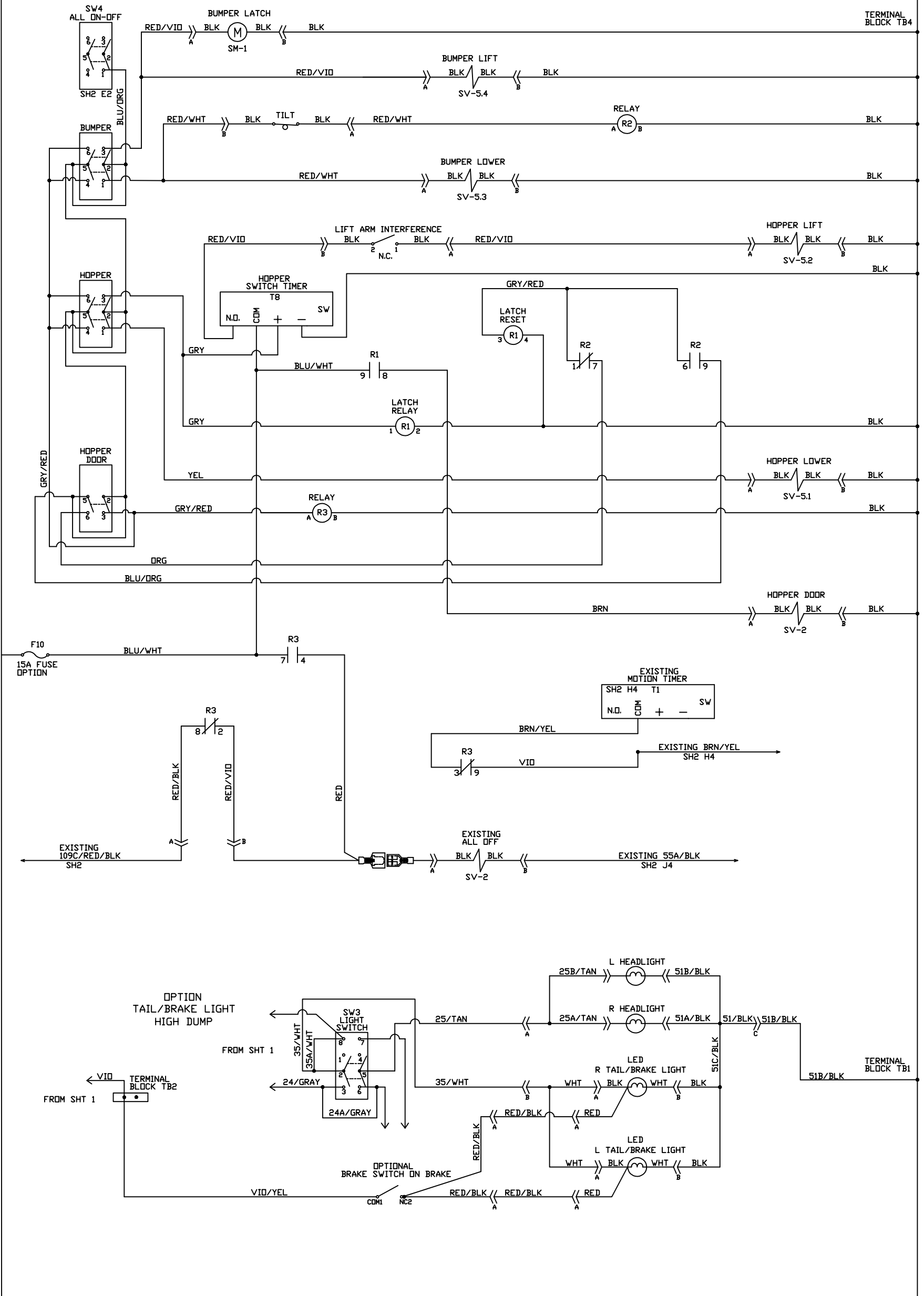

OPTION
TAIL/BRAKE LIGHT
HIGH DUMP

FROM SHT 1

FROM SHT 1

CONFIDENTIAL									
THIS DRAWING AND ALL INFORMATION CONTAINED HEREIN ARE THE EXCLUSIVE PROPERTY OF MINUTEMAN INTERNATIONAL, INC. THIS DRAWING IS NOT TO BE COPIED OR OTHERWISE REPRODUCED WITHOUT EXPRESSED WRITTEN PERMISSION OF MINUTEMAN INTERNATIONAL, INC. IN ADDITION, THIS DRAWING MUST BE RETURNED UPON REQUEST. FURTHER, ALL INFORMATION CONTAINED HEREIN MUST BE MAINTAINED CONFIDENTIAL.									
TITLE NAUTILUS ELECTRICAL SCHEMATIC								SCALE NTS	
MATERIAL N/A					FINISH N/A				
TOLERANCES (UNLESS OTHERWISE SPECIFIED)					REMOVE BURRS AND BREAK SHARP EDGES .005/.020				
0-1" ± 1/16		.000 ± .005		SIZE B		DRAWN BY KHH		DATE 08/03/15	
>1-12" ± 1/4"		.00 ± .010		CHECKED BY JWP		DATE 08/03/15			
<12" ± 1/2"		ANGLES ± 30'							
REV E.C.N.		DATE		CHANGE		BY CHK BY		REV	
						14N845 U.S. ROUTE 20 PINGREE GROVE, IL 60140		P.N. 748992-1	
						SHEET 4 OF 6		J	

5/RED

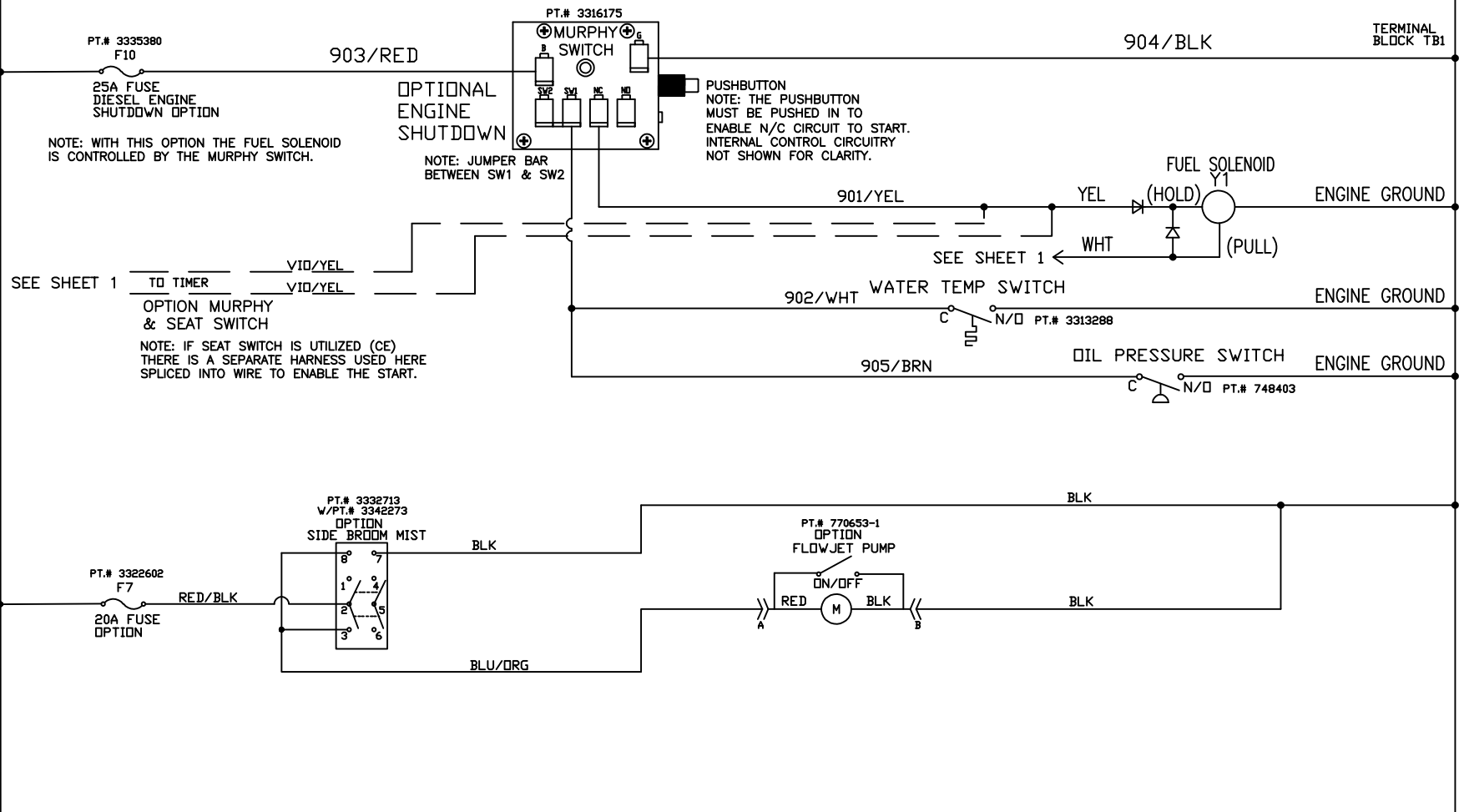

(DIESEL ONLY)

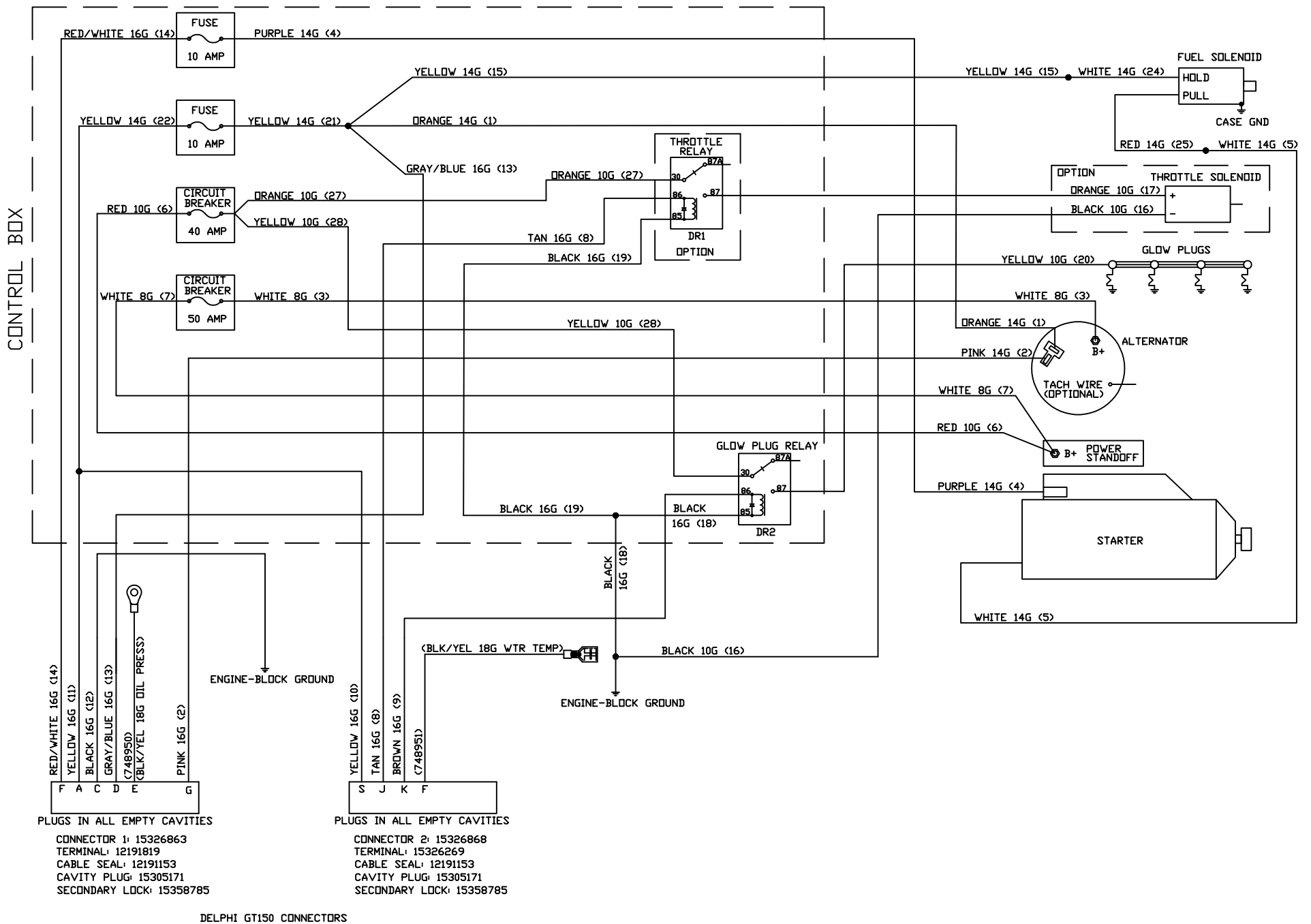

SEE SHEET 1

CONFIDENTIAL			
THIS DRAWING AND ALL INFORMATION CONTAINED HEREIN ARE THE EXCLUSIVE PROPERTY OF MINUTEMAN INTERNATIONAL, INC. THIS DRAWING IS NOT TO BE COPIED OR OTHERWISE REPRODUCED WITHOUT EXPRESSED WRITTEN PERMISSION OF MINUTEMAN INTERNATIONAL, INC. IN ADDITION, THIS DRAWING MUST BE RETURNED UPON REQUEST. FURTHER, ALL INFORMATION CONTAINED HEREIN MUST BE MAINTAINED CONFIDENTIAL.			
TITLE NAUTILUS ELECTRICAL SCHEMATIC			SCALE NTS
MATERIAL N/A		FINISH N/A	
TOLERANCES (UNLESS OTHERWISE SPECIFIED) REMOVE BURRS AND BREAK SHARP EDGES .005/.020			
0-1" ± 1/16	.00 ± .005	SIZE	DRAWN BY KHH DATE 08/03/15
>1-12" ± 1/4"	.00 ± .010	B	CHECKED BY JWP DATE 08/03/15
<12" ± 1/2"	ANGLES ± 30'		
		P.N. 748992-1	
14N845 U.S. ROUTE 20 PINGREE GROVE, IL 60140		SHEET 5 OF 6	
REV	E.C.N.	DATE	CHANGE
BY	CHK	BY	

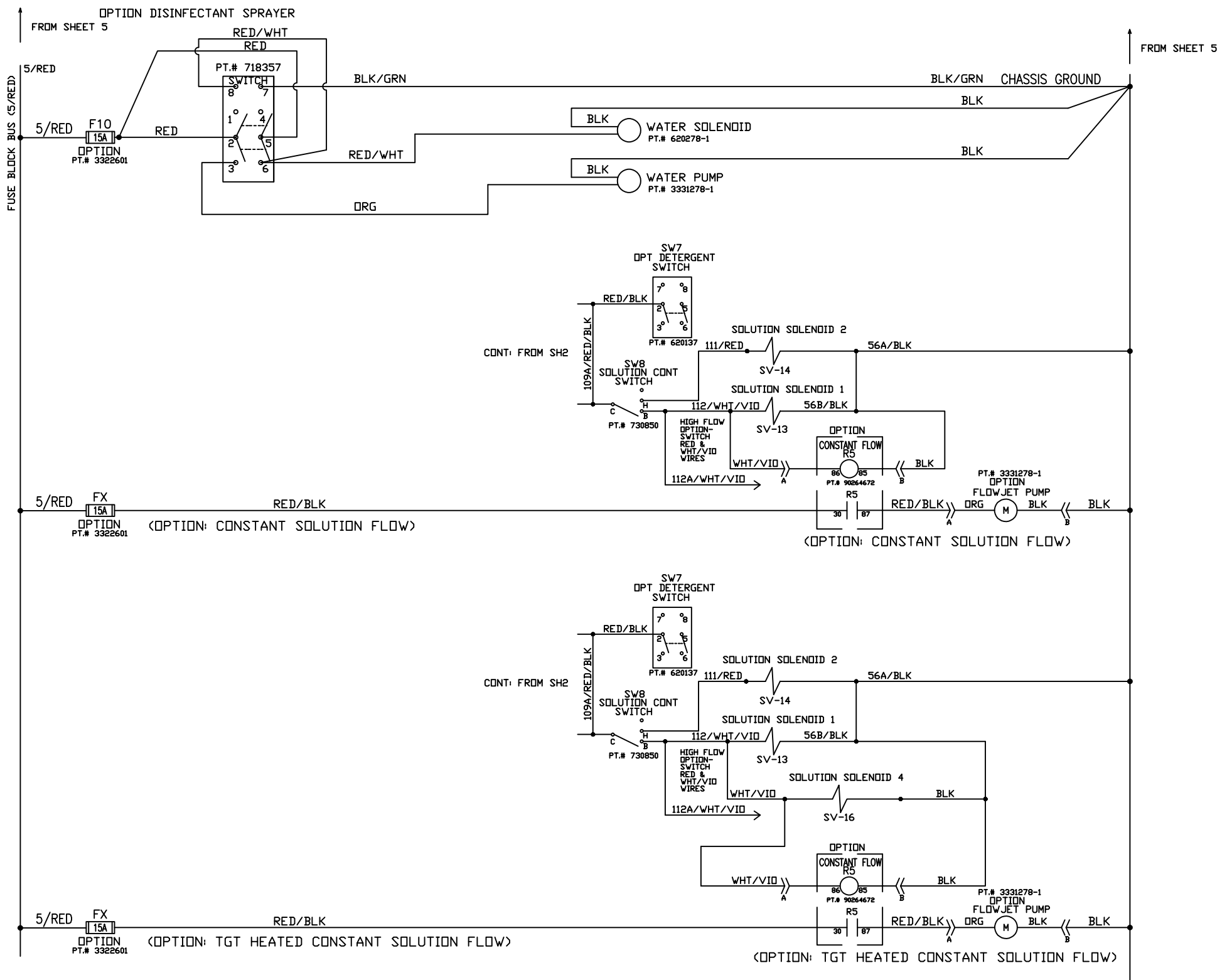

(GAS/LP ONLY)

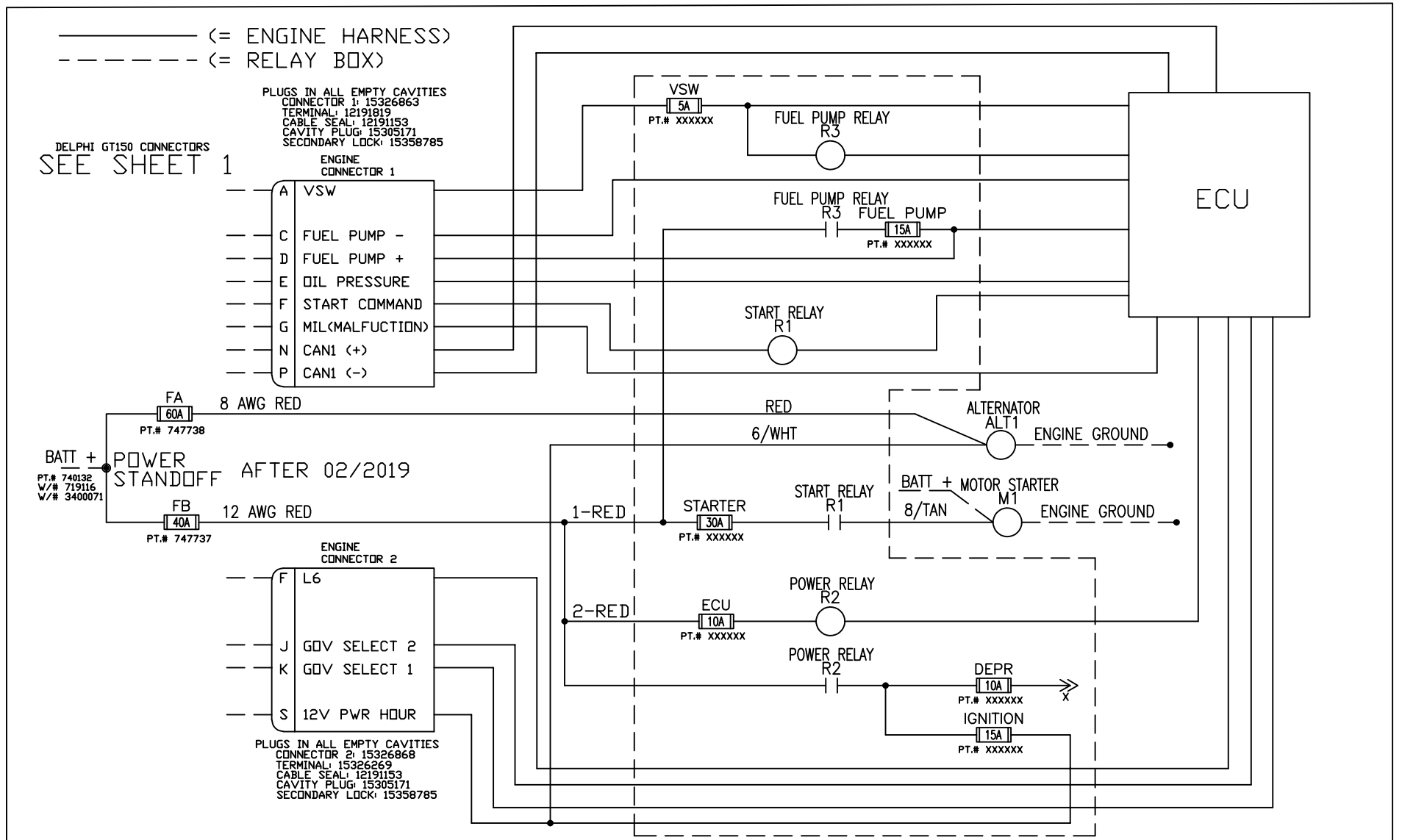

CONFIDENTIAL

THIS DRAWING AND ALL INFORMATION CONTAINED HEREIN ARE THE EXCLUSIVE PROPERTY OF MINUTEMAN INTERNATIONAL, INC. THIS DRAWING IS NOT TO BE COPIED OR OTHERWISE REPRODUCED WITHOUT EXPRESSED WRITTEN PERMISSION OF MINUTEMAN INTERNATIONAL, INC. IN ADDITION, THIS DRAWING MUST BE RETURNED UPON REQUEST. FURTHER, ALL INFORMATION CONTAINED HEREIN MUST BE MAINTAINED CONFIDENTIAL.

TITLE NAUTILUS ELECTRICAL SCHEMATIC SCALE NTS

MATERIAL N/A FINISH N/A

REV	E.C.N.	DATE	CHANGE	BY	CHK BY
J	151969	02/02/22	ADD CONSTANT SOLUTION FLOW OPTIONS	KHH	KHH
H	151293	04/09/20	UPDATED MURPHY SWITCH	KHH	KHH
G	150567	02/06/19	ADDED SIDE BROOM MIST OPTION	KHH	KHH
F	150447	10/18/18	ADD BRAKE LIGHTS	KHH	KHH

TOLERANCES (UNLESS OTHERWISE SPECIFIED)		REMOVE BURRS AND BREAK SHARP EDGES .005/.020	
0-1"	± 1/16	SIZE	DRAWN BY KHH
>1-12"	± 1/4"	B	CHECKED BY JWP
<12"	± 1/2"		DATE 08/03/15
		DATE 08/03/15	

14N845 U.S. ROUTE 20 PINGREE GROVE, IL 60140		P.N. 748992-1	
SHEET 6 OF 6		REV J	

MOTION T1

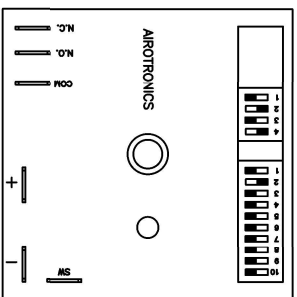

SHUT DOWN T2

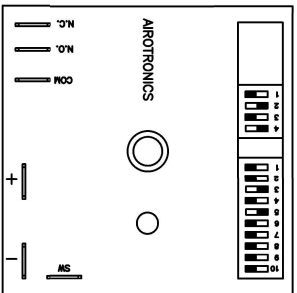

FLOAT T3

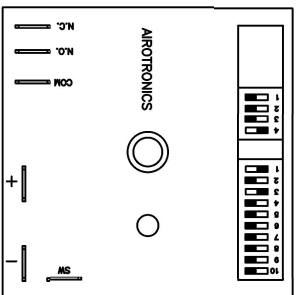

ENGINE T4

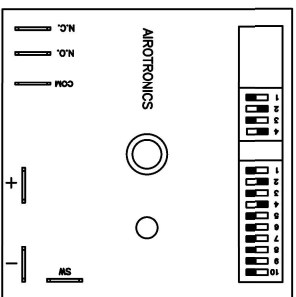

VAC T5

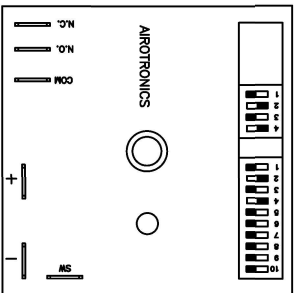

SQUEEGEE T6

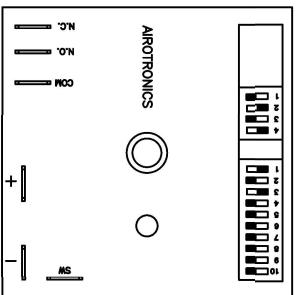

CE SEAT SWITCH T7

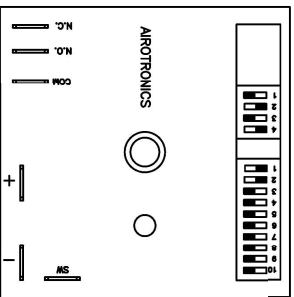

TIMER PLATE SETTINGS
HIGH DUMP - HOPPER T8

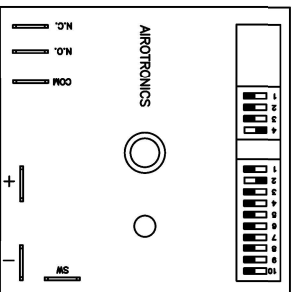

TIMER
PT# 748430

PROP VALVE DRIVER
SINGLE SOLENOID

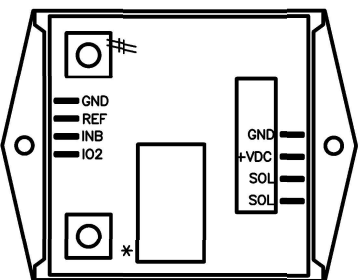

DRIVER
PT# 731125

SETTINGS:
P1 TO 1.52
P2 TO 1.75
P3 TO 1.92
P4 TO 0.00
UP TO 00.5
DN TO 00.5
DF TO 60
SAVE:
TURN LEFT
KNOB 1 TURN

PROP VALVE DRIVER
DOUBLE SOLENOID

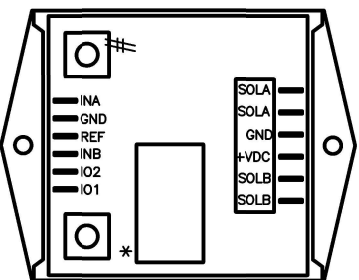

DRIVER
PT# 731126

SETTINGS:
BP1 TO 1.52
BP2 TO 1.75
BP3 TO 1.92
BP4 TO 0.00
AP1 TO 1.6
AP2 TO 1.7
AP3 TO 1.85
AP4 TO 0.00
AUP TO 00.5
ADN TO 00.5
BUP TO 00.5
BDN TO 00.5
DF TO 60
SAVE:
TURN LEFT
KNOB 1 TURN

NAUTILUS & HIGH DUMP - TIMERS & DRIVERS

CONFIDENTIAL

THIS DRAWING AND ALL INFORMATION CONTAINED THEREIN ARE THE EXCLUSIVE PROPERTY OF MINUTEMAN INTERNATIONAL, INC. THIS DRAWING IS NOT TO BE COPIED OR OTHERWISE REPRODUCED WITHOUT EXPRESSED WRITTEN PERMISSION OF MINUTEMAN INTERNATIONAL, INC. IN ADDITION, THIS DRAWING MUST BE RETURNED UPON REQUEST. FURTHER, ALL INFORMATION CONTAINED HEREIN MUST BE MAINTAINED CONFIDENTIAL.

TITLE	TIMER DIP-SWITCH SETTINGS	SCALE	NTS
MATERIAL	N/A	FINISH	N/A

TOLERANCES (UNLESS OTHERWISE SPECIFIED)	REMOVE BURRS AND BREAK SHARP EDGES	.005/.020
0-.1" ± 1/16	SIZE	DRAWN BY MB
>1-.12" ± 1/4"	CHECKED BY JWP	DATE 12/05/13
<12" ± 1/2"	ANGLES ± 30	DATE 01/15/14

REV	D	152252	12/16/22	CHANGE PROP VALVE DRIVERS SETTINGS	KHH	BY	KHH
REV		E.C.N.	DATE	CHANGE	CHK	BY	CHK

14845 U.S. ROUTE 20
P.N. 731224-R
PINCREE GROVE, IL 60140
SHEET OF

Key on all switches off

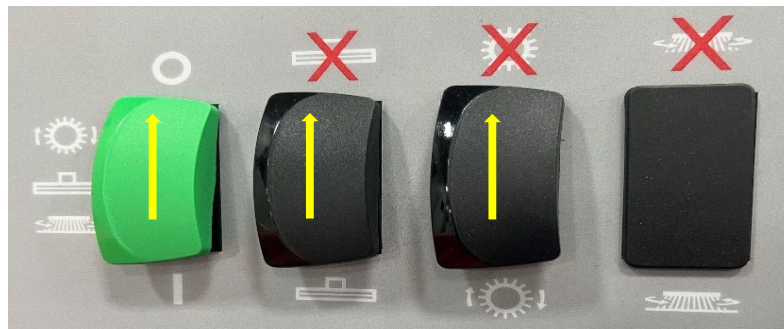
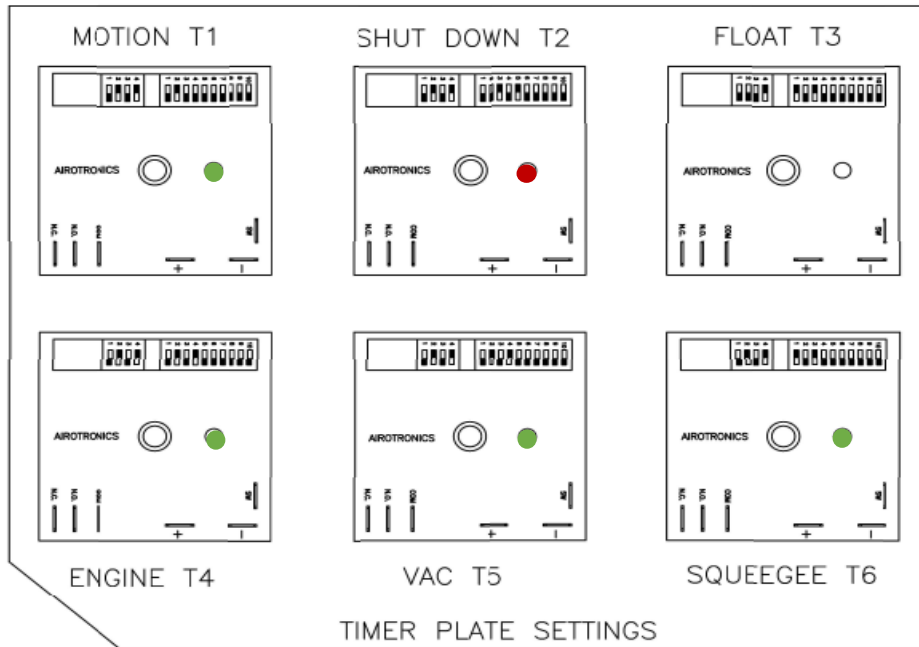

Green
"One Touch"
Switch

Squeegee

Scrub
Brush Switch

All switches are in the off position and key is on and directional control pedal is in neutral position. This is what timer lights should be.

Key on one touch on all other switches off

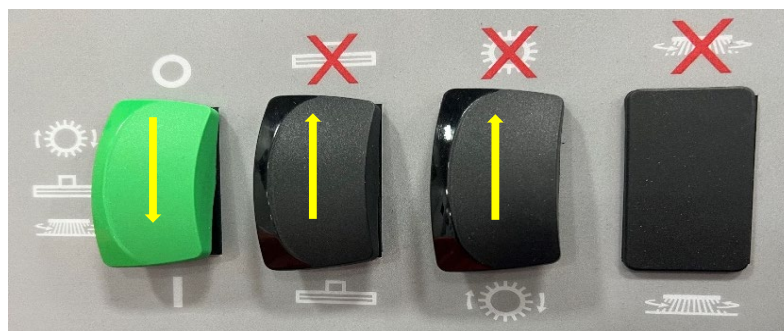
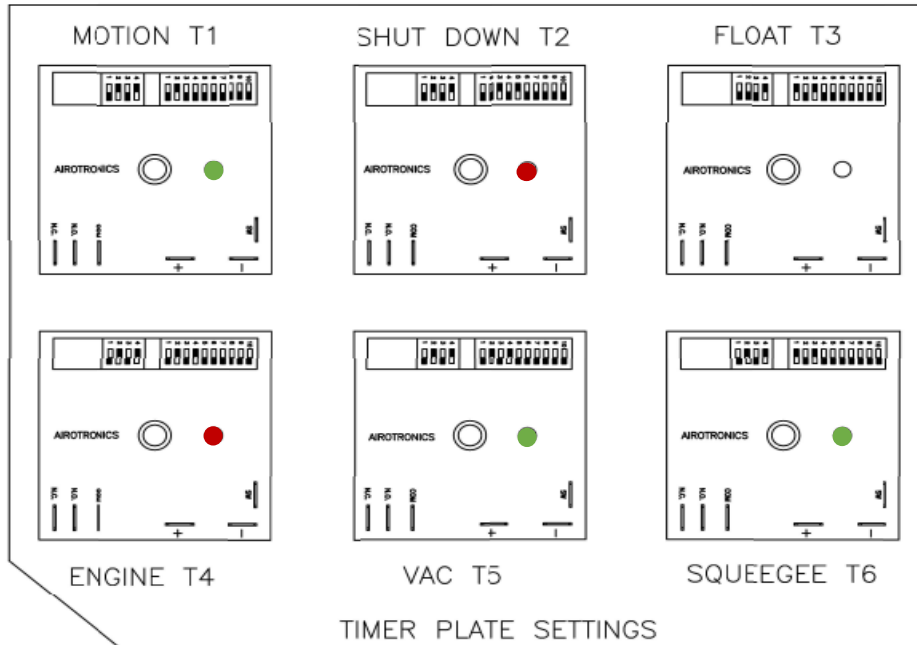

Green
"One Touch"
Switch

Squeegee

Scrub
Brush Switch

Green one touch switch is on, all other switches are off and directional control pedal is in neutral position. This is what timer lights should be.

Key on One touch and Scrub switches on

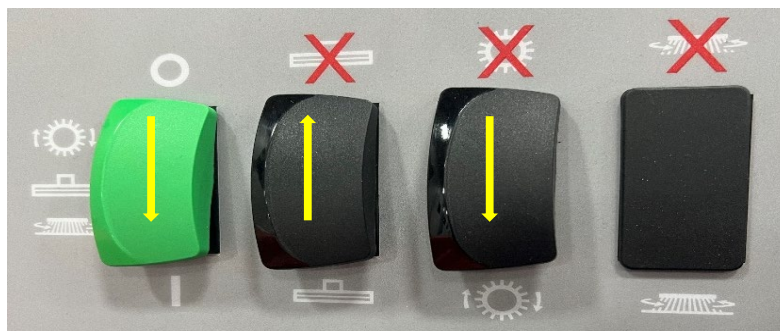
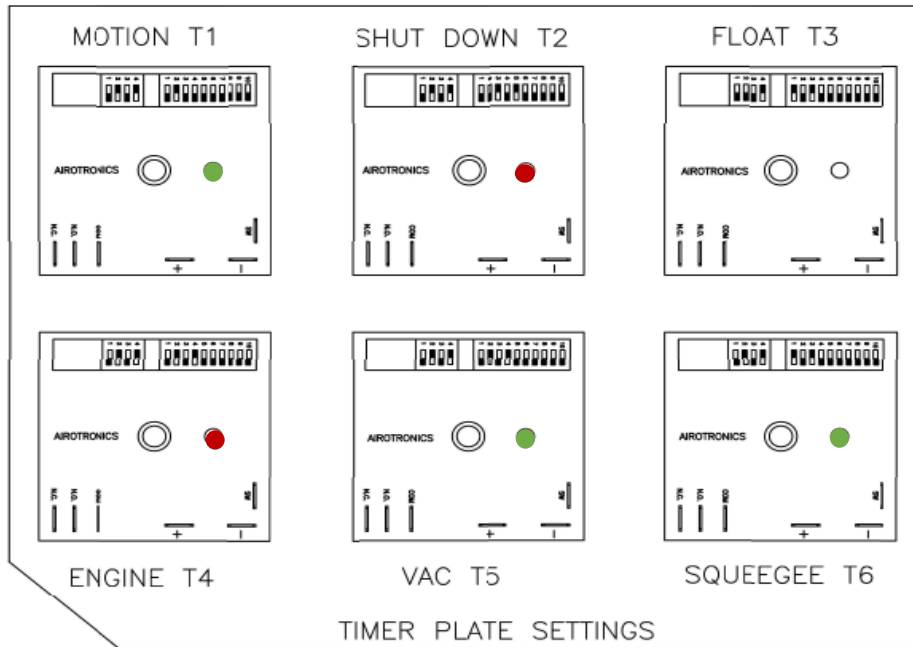

Green
"One Touch"
Switch

Squeegee

Scrub
Brush Switch

Green one touch switch and Scrub brush switch are on and Squeegee switch is off and directional control pedal is in neutral position. This is what timer lights should be.

Key on all switches on

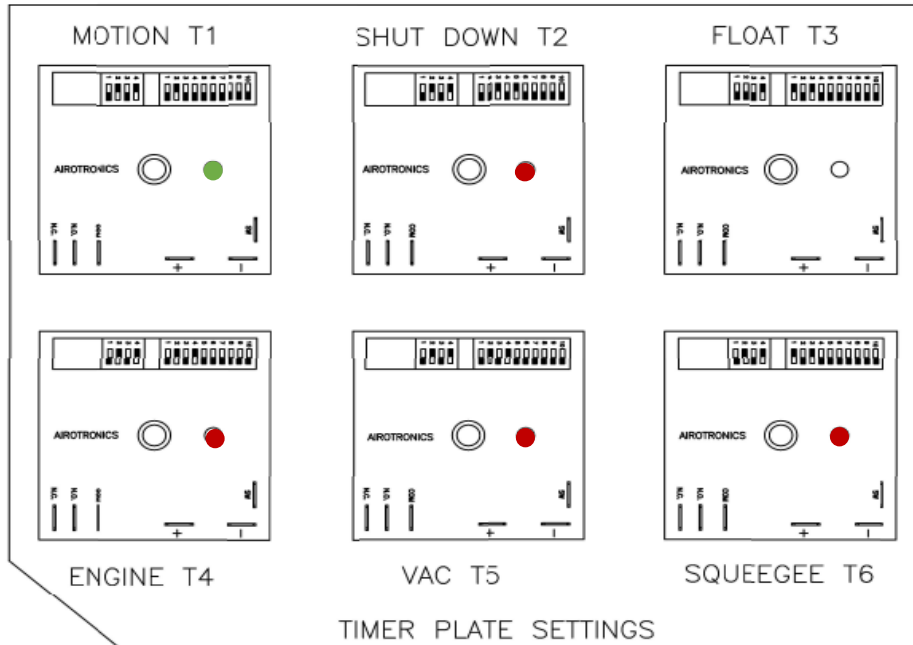

Green
"One Touch"
Switch

Squeegee

Scrub
Brush Switch

All switches are in the on position and key is on and directional control pedal is in Neutral position. This is what timer lights should be.

Key on All switches on Directional control pedal is Forward

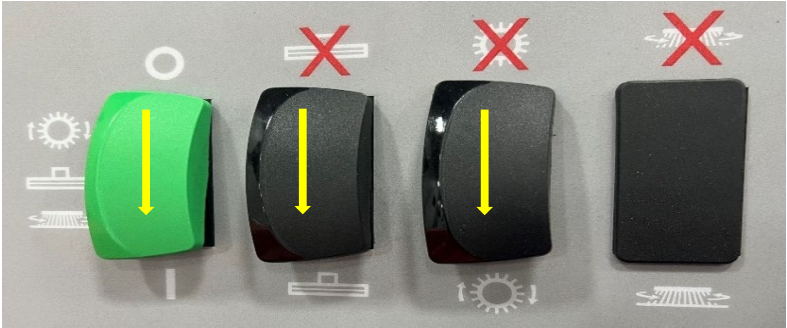
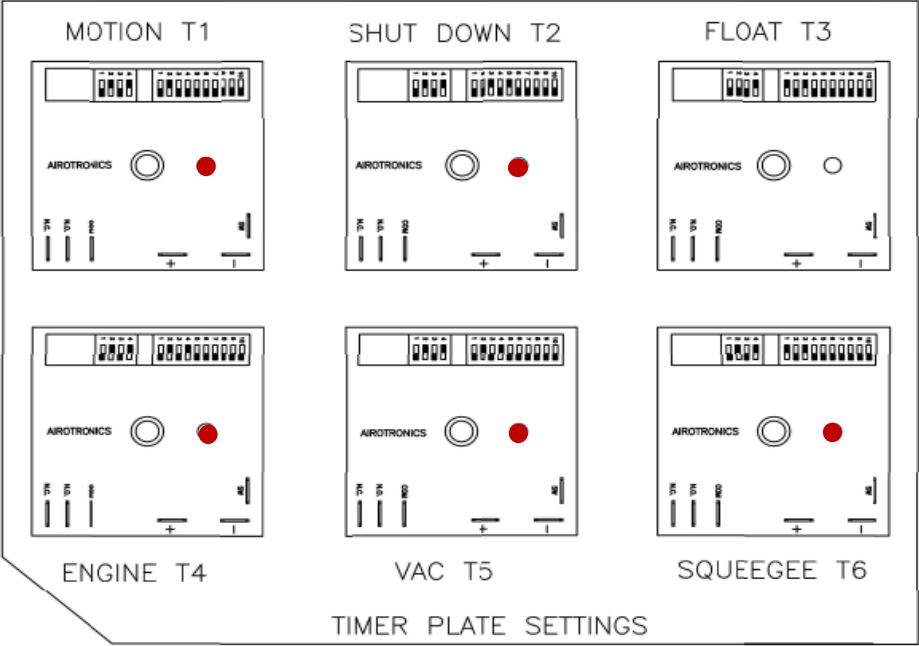

Green
"One Touch"
Switch

Squeegee

Scrub
Brush Switch

All switches are in the on position and key is on and directional control pedal is in Forward position. This is what timer lights should be.

Key on All switches on Directional control pedal is Neutral

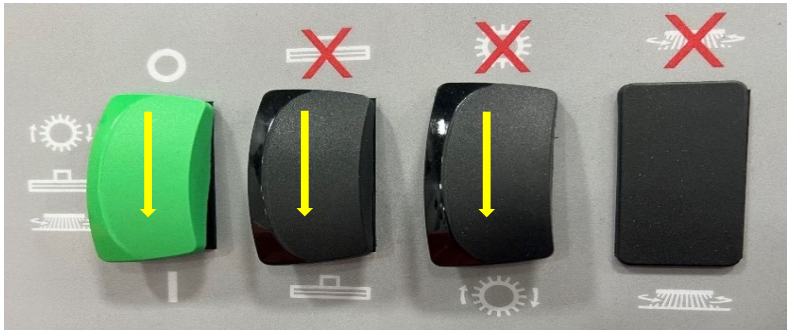
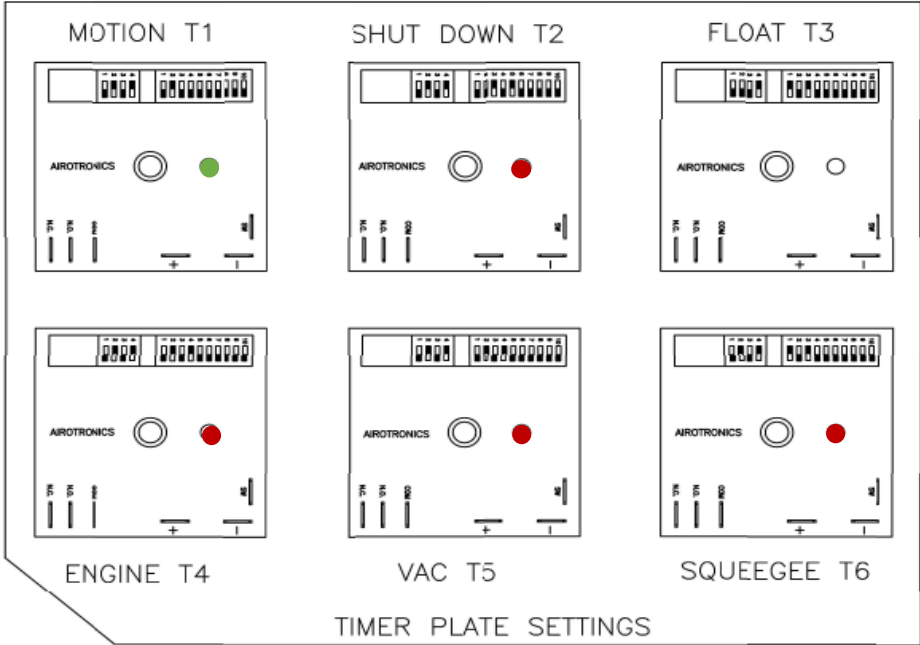

Green
"One Touch"
Switch

Squeegee

Scrub
Brush Switch

All switches are in the on position and key is on and directional control pedal is released from Forward to the Neutral position. After about 5 seconds T1 will change from red to green. This is what timer lights should be.

Key on All switches on Directional control pedal is Reverse

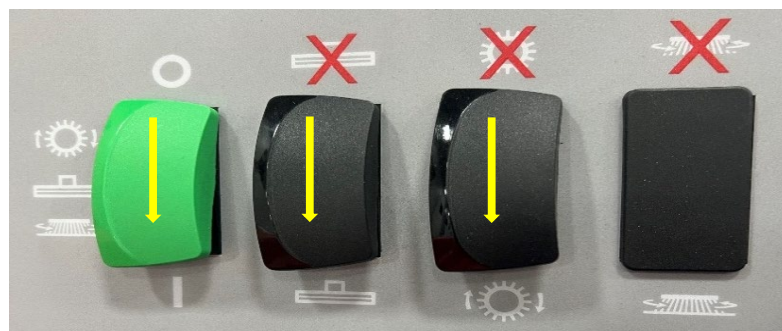
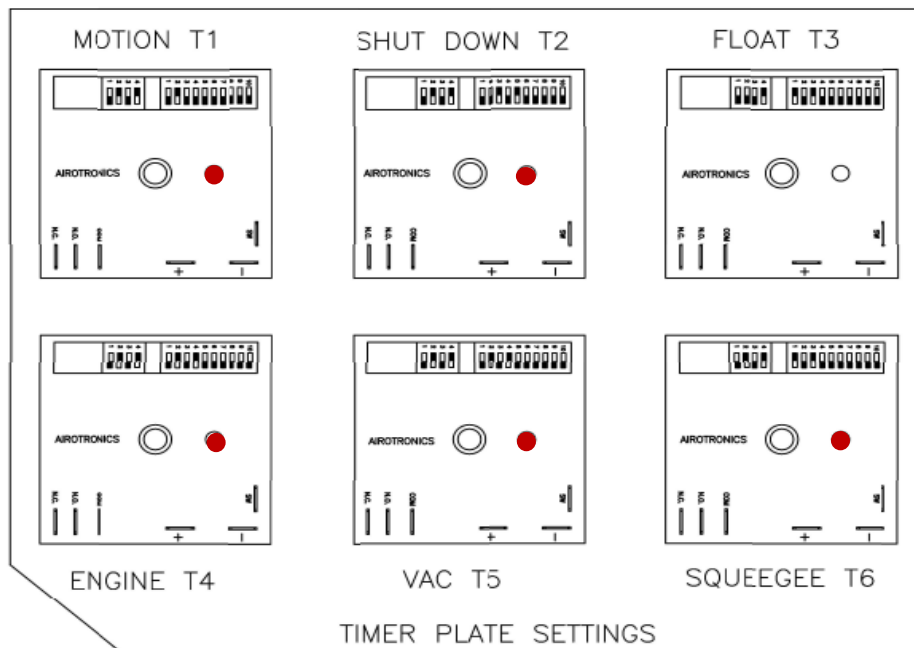

Green
"One Touch"
Switch

Squeegee

Scrub
Brush Switch

All switches are in the on position and key is on and directional control pedal is in Reverse position. This is what timer lights should be.

Squeegee switch turned off

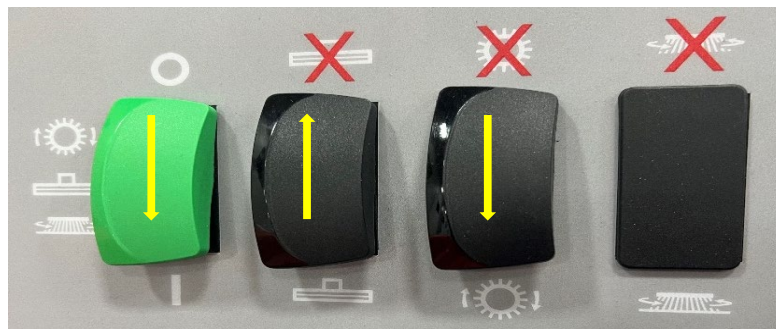
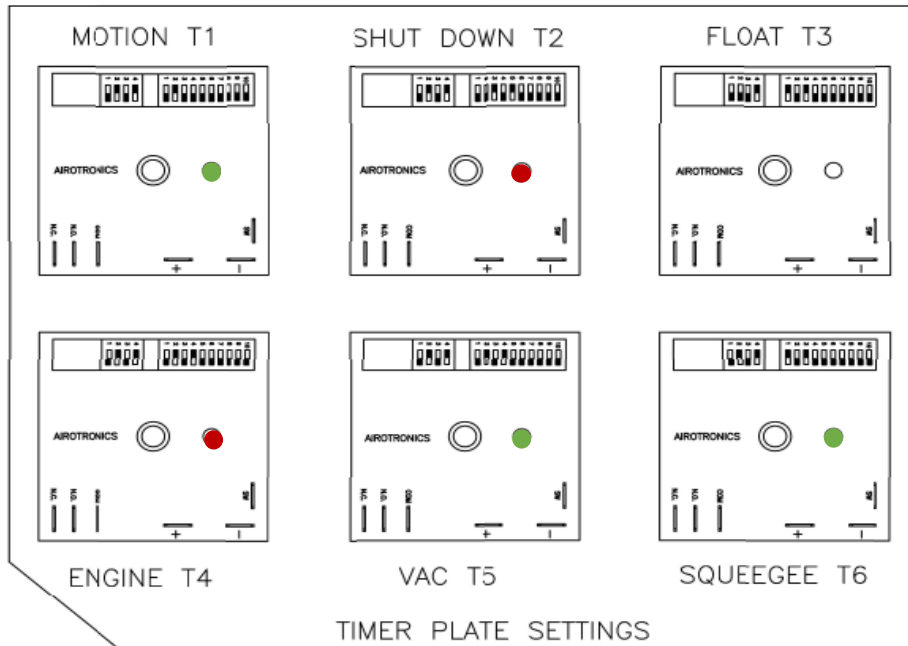

Green
"One Touch"
Switch

Squeegee

Scrub
Brush Switch

After Squeegee switch turned off T6 will turn green after 5 seconds and T5 will turn green after 10 more seconds.

Key on One touch and Squeegee switches on

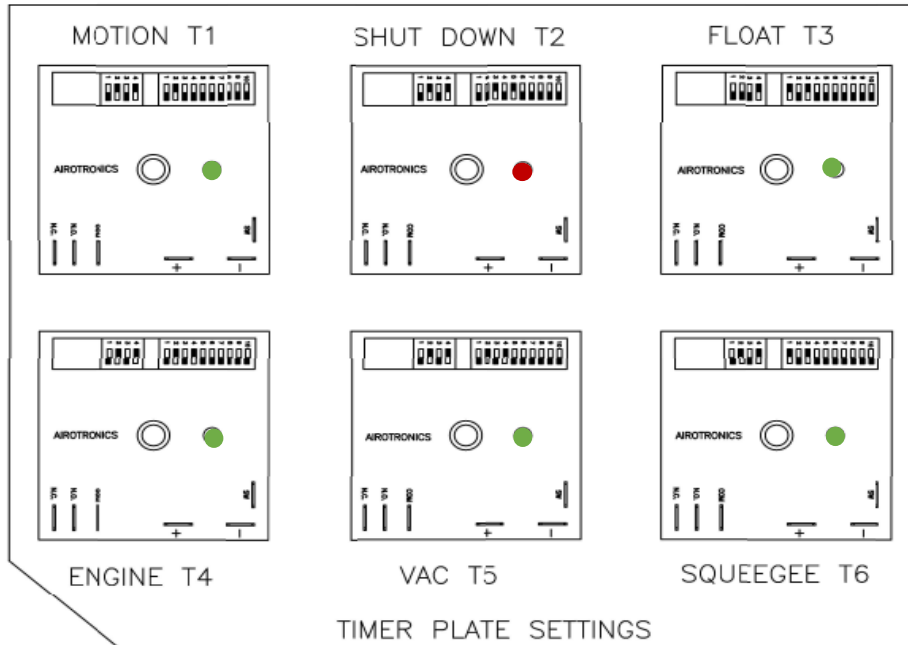

Green
"One Touch"
Switch

Squeegee

Scrub
Brush Switch

Green one touch and Squeegee switches on. When recovery tank float is triggered the light on T3 will turn green. After 10 more seconds T3 will turn red and then T2 will turn green and T5 and T6 will turn off.

NAUTILUS HYDRAULIC MANIFOLD OPERATION

MAIN HYDRAULIC MANIFOLD

The main hydraulic manifold performs the following functions:

- Main brush system pressure relief
- Main brushes on and off
- Scrub head raise and lower
- Scrub head lock in the raised position
- Main brush scrubbing force
- Squeegee raise and lower
- Squeegee lock in the raised position

Location and operation of the individual main scrub brush hydraulic valves:

The following six (of ten) solenoid valves that control main brush functions receive hydraulic pressure and flow from the front auxiliary pump which has a displacement of .84 cu. In./rev. and supplies a nominal flow of 8.7 gpm.

Hydraulic fluid controlled by the following six main brush system valves enters the manifold through port P2.

PRESSURE RELIEF VALVE RV2 in port 9.1 provides pressure relief. This valve allows a maximum system pressure of 2500 psi.

This valve dumps to tank through port T2

SOLENOID VALVE SV2 (All off) in port 7.1 is a 2-position 2-way normally-open control valve.

When de-energized this valve opens a direct path from the pressurized side of the manifold to tank.

When energized this solenoid closes the direct path from the pressurized side of the manifold to tank.

This valve opens to tank through port T2

CHECK VALVE CV1 in port 8 prevents the main brushes from rotating due to system back pressure when the brushes are turned off.

SOLENOID VALVE SV3 (Main brushes on-off) in port 3.2 is a 2-position 2-way normally-closed control valve.

When de-energized this valve prevents flow to the main brush motors.

When energized this solenoid opens and provides pressurized flow to the main brush motors.

This valve directs the fluid flow to the motors through port MB-OUT

PROPORTIONAL REDUCTION VALVE SV4 (Main brush force) in port 6.1.

This valve controls main brush scrubbing force (against the floor) by regulating the fluid pressure to the rod-end of the scrub head lift cylinder.

SOLENOID VALVE SV5 (Main brushes down) in port 5.1 is a 2-position 3-way directional control valve.

When de-energized this valve directs flow from the rod-end of the scrub head lift cylinder to tank.
When energized it directs regulated pressure to the rod-end of the scrub head lift cylinder.
This valve directs the flow to the scrub head lift cylinder through port BL B.

The following two main brush system solenoids receive hydraulic pressure generated by the back-pressure of the steering system and additional back pressure provided by an orifice located just before the pressure inlet of the power steering unit (a total of approximately 700 psi). The power steering unit is powered by the rear auxiliary pump which has a displacement of .40 cu. In./rev. and supplies a nominal flow of 4.2 gpm.

Hydraulic fluid controlled by these two scrub brush valves enters the manifold through PORT P1.

REDUCING VALVE RV3 in port 4.1 limits the hydraulic pressure to the piston-end of the scrub head lift cylinder to a maximum of 450 psi.

SOLENOID VALVE SV6 (Main brushes up-locked) in port 3.1 is a 2-position 2-way normally-open control valve.

When de-energized this valve allows flow into the piston-end of the scrub head lift cylinder while preventing flow out from the piston-end of the scrub head lift cylinder (scrub head raise and lock).
When energized this solenoid allows a maximum of 450 psi fluid flow (from reducing valve RV3) into and out from the piston-end of the scrub head lift cylinder.

This valve directs the flow to and from the piston-end of the scrub head cylinder through port BL A.

Location and operation of the individual squeegee hydraulic valves:

The two solenoids that control squeegee functions receive hydraulic pressure from the back-pressure of the power steering unit (a total of approximately 700 psi). The power steering unit is powered by the rear auxiliary pump which has a displacement of .40 cu. In./rev. and supplies a nominal flow of 4.2 gpm.

Hydraulic fluid that powers the squeegee lift system enters the manifold through PORT P1.

Pressure relief is provided by the pressure relief valve in the power steering unit which allows a maximum pressure of 1200 psi.

SOLENOID VALVE SV7 (Squeegee up-down) in port 1 is a 2-position 4-way directional control valve.
When de-energized this valve directs pressurized fluid to the piston-end of the squeegee lift cylinder while directing the fluid from the rod-end of the squeegee lift cylinder to tank through port T1. (Squeegee raised).

When energized it directs pressurized fluid to the rod-end of the squeegee lift cylinder while directing the fluid from the piston-end of the squeegee lift cylinder to tank through port T1. (Squeegee lowered).

CHECK VALVE CV2 in port 2 is a pilot-operated check valve that holds the squeegee in the raised position when the system is off.

When the rod-end of the squeegee lift cylinder is pressurized the check valve is held open allowing the squeegee to lower.

VACUUM IMPELLER HYDRAULIC MANIFOLD

The vacuum impeller hydraulic manifold performs the following functions:

Pressure relief
Vacuum impeller on and off

Location and operation of the individual vacuum impeller hydraulic valves:

The solenoids that control vacuum impeller functions receives hydraulic pressure and flow from the center auxiliary pump which has a displacement of .66 cu. In./rev. and supplies a flow of 6.8 gpm.

Hydraulic fluid that powers the vacuum impeller enters the manifold through PORT P.

PRESSURE RELIEF VALVE RV1 in port 9.2 provides pressure relief. This valve allows a maximum pressure of 2500 psi.

This valve dumps to tank through port T

SOLENOID VALVE SV1 (Impeller on-off) in port 7.2 is a 2-position 2-way normally-open control valve. When de-energized this valve allows fluid to by-pass the impeller motor and return to tank. When energized this solenoid closes the return to tank and directs the pressurized fluid flow to the vacuum impeller motor inlet through port VF OUT.

The outlet side of the impeller motor goes to port VF IN and back to tank through port T.

DETAILED SYSTEM OPERATION:

Scrub brushes:

The "ALL ON-OFF" rocker switch (green switch) and the "BRUSHES OFF" rocker switch, which is downstream and in series with the "ALL ON-OFF" switch, always apply electrical power to and remove power from solenoid valves SV2, SV3, SV4, SV5, and SV6 at the same time.

When both of these switches are closed solenoid valve SV2 (all off) is energized and blocks the fluid flow to tank.

Solenoid SV3 (main brushes on) is energized directing pressurized fluid to the scrub brush motors. The brushes begin to rotate.

Solenoid valve SV6 (main brushes up-lock) is energized which un-locks the scrub head from its raised position and allows fluid flow to and from the piston-end of the scrub head cylinder.

Solenoid SV5 (main brushes down) is energized allowing regulated hydraulic pressure to the rod-end of the scrub head lift cylinder causing the scrub head to lower.

Proportional reduction valve SV4 (Main brush force) is energized and regulates the hydraulic pressure applied to the rod-end of the scrub head lift cylinder. This provides the variable brush force against the floor.

Controlling brush pressure:

The green "ALL ON-OFF" switch also provides power for the proportional valve driver which controls the Proportional reduction valve SV4 (Main brush force).

The operator selects the desired brush scrubbing force by turning the brush force rotary switch, located on the instrument panel, to one of three switch positions, low, medium, and high. The rotary switch provides three separate signals to the proportional valve driver input terminals IN B and IO 2.

IN B low and IO 2 low = Low brush force

IN B high and IO 2 low = medium brush force

IN B low and IO 2 high = high brush force

With a brush force selected, the proportional valve driver sends a signal to the proportional reduction valve SV4 which controls the hydraulic pressure that is applied to the rod-end of the scrub head lift cylinder. This pressure acts against the controlled pressure which is constantly applied to the piston-end of the cylinder causing the scrub head to lower and providing the correct brush force against the floor.

A note on the operation of the scrub head lift cylinder:

The hydraulic pressure supplied by the proportional reduction valve alone would provide more scrub brush force against the floor than is desired. For this reason a constant balancing hydraulic pressure of 450 psi is applied to the opposite side of the cylinder piston. In addition, when the pressure is removed from the proportional reduction valve, the 450 psi balancing pressure is utilized to raise the scrub head to its storage position.

Additional scrubbing control switch and timer:

When the scrub brushes are down and turning but the machine is not in motion, a neutral switch, located on the hydraulic propulsion pump mount, opens triggering a true-off-delay 5-second timer (motion timer). If the machine remains motionless for 1.5 seconds the timer will interrupt the electrical power to solenoid SV2 (all on-off) and SV3 (main brushes on) which will turn off the scrub brushes (the flow of cleaning solution will also turn off). As soon as the machine starts to move the neutral switch closes, the timer returns power to solenoid SV2 and SV3, and the brushes turn on.

CMK 9-17-2015

OPTIONAL SIDE SCRUB BRUSH HYDRAULIC MANIFOLD OPERATION

The side scrub brush hydraulic manifold performs the following functions:

- Side brush on and off
- Side scrub head raise and lower
- Side scrub head locked in the raised position
- Side brush scrubbing force
- Side brush extend and retract

Location and operation of the individual side scrub brush hydraulic valves:

The following single solenoid valve that controls side brush on-off function receives hydraulic pressure and flow from port P2. This fluid is received downstream from the two main scrub brush motors. This fluid originates from the front auxiliary pump which has a displacement of .84 cu. In./rev. and supplies a nominal flow of 8.7 gpm.

Pressure relief is provided by relief valve RV1 in the main manifold. This valve allows a maximum pressure of 2500 psi. This valve dumps to tank through port T2

SOLENOID VALVE SV8 (Side brush on-off) in port 7.2 is a 2-position 2-way normally-open control valve. When de-energized this valve allows flow to bypass the side brush motor. When energized this solenoid closes the bypass and directs pressurized flow to the side brush motor. This valve directs the fluid flow to the motor through port MB-IN and back into the manifold through port SB OUT then back to tank through port T2.

The following five side brush system solenoids receive hydraulic pressure from the center auxiliary pump which has a displacement of .66 cu. In./rev. and supplies a flow of 6.8 gpm. This fluid comes from a tee in the steering unit pressure port just below (upstream from) the orifice.

PROPORTIONAL REDUCTION VALVE SV9 (Side brush force) in port 6.2.

This valve controls side brush scrubbing force (against the floor) by regulating the fluid pressure to the piston-end of the scrub head lift cylinder.

SOLENOID VALVE SV10 (Side brush down) in port 5.3 is a 2-position 3-way directional control valve. When de-energized this valve directs flow from the piston-end of the side brush lift cylinder to tank. When energized it directs regulated pressure to the piston-end of the side brush lift cylinder. This valve directs the flow to the side brush lift cylinder through port SBLA.

REDUCING VALVE RV4 in port 4.2 limits the hydraulic pressure to the rod-end of the side brush lift cylinder to a maximum of 450 psi.

SOLENOID VALVE SV11 (side brush up-locked) in port 3.2 is a 2-position 2-way normally-open control valve.

When de-energized this valve allows flow into the rod-end of the side brush lift cylinder while preventing flow out from the rod-end of the side brush lift cylinder (scrub head raise and lock).

When energized this solenoid allows a maximum of 450 psi fluid flow (from reducing valve RV4) into and out from the rod-end of the side brush lift cylinder.

This valve directs the flow to and from the piston-end of the side brush lift cylinder through port SBLB.

SOLENOID VALVE SV12 (Side brush Extend-retract) in port 5.2 is a 2-position 3-way directional control valve.

When de-energized this valve directs fluid from the piston-end of the side brush extend cylinder through port SBEA to tank through port T1 (side brush retracted).

When energized it directs pressurized fluid to the piston-end of the squeegee lift cylinder through port SBEA (side brush extended).

Note: The rod end of the side brush extend cylinder always has line pressure from port SBEB. With equal pressure on both sides of the piston the cylinder operates using the difference in area between the piston with the rod and the piston without the rod.

CMK 10-10-2014

NAUTILUS DUAL CONTROLLER ADJUSTMENT FOR MAIN SCRUB BRUSH AND OPTIONAL SIDE SCRUB BRUSH FLOOR PRESSURE ADJUSTMENT.

MAIN SCRUB HEAD:

Note: the following 12 steps are required only for the factory or if you are replacing the reduction valve 730702 in port 4.1. If the part number on the side of the reduction valve body (not the coil but the cartridge body) ends with the number 45 then it is already set at 450 psi and the following 12 steps can be skipped.

Before the main scrub head floor pressure adjustment can be performed the reduction valve at the main hydraulic manifold port 4.1 must be adjusted to 450 psi (The purpose of this valve is to change the variable inlet pressure (approximately 700 psi) to a constant output pressure of 450 psi which is applied to the piston-end of the scrub head lift cylinder. 450 psi is the pressure required to raise the main scrub head at “high” engine rpm).

If the part number on the side of the reduction valve body in port 4.1 (not the coil but the cartridge body) ends with the number 45 then it is already set at 450 psi. If this valve has already been adjusted go to “Setting the main scrub brush floor pressure controller”.

To adjust the reduction valve on the main manifold at port 4.1:

1. Install a tee fitting with a gauge port between the main hydraulic hose and the hydraulic manifold at port BLA.
2. Attach a suitable hydraulic pressure gauge to the gauge port in the tee fitting.
3. Zero the pressure gauge if necessary.
4. Loosen the lock nut on the adjustment stud on the reduction valve located on the main hydraulic manifold at port 4.1
5. Ensure that the green “One-Touch” switch is in the off position.
6. Start the engine
7. Set the throttle switch to high.
8. Turn the reduction valve adjustment stud clockwise until the pressure gauge reads 450 psi.*(Note: It is not possible to attain 450 psi if the restrictor orifice fitting is not installed at the power steering unit pressure port.)*
9. Tighten the reduction valve locknut.
10. Verify the pressure reading.
11. Turn off the engine.
12. Replace the hydraulic hose at port BLA.

Description of the main scrub brush floor pressure settings (Using the dual proportional valve driver):

The dual controller uses an “A” prefix for the optional side brush settings and a “B” prefix for the Main brush settings.

The dual floor brush pressure controller or dual proportional valve driver (located on the left front face of the operator console) provides three separate brush floor pressure forces for the main scrub brushes by controlling the hydraulic pressure output of the SV4 proportional reduction valve located on the main hydraulic manifold at port 6.1. and provides three separate brush floor pressure forces for the side scrub brush by controlling the hydraulic pressure output of the SV9 proportional reduction valve located on the SSB hydraulic manifold at port 6.2.

For the main scrub brushes this variable output pressure is applied to the rod-end of the scrub head lift cylinder. This variable pressure is balanced against the steady 450 psi at the piston-end of the cylinder (provided by the reduction valve) to achieve the desired scrub brush floor pressure.

The controller has a left control knob, a right control knob, and an information screen. The right control knob scrolls between the various parameters. The left control knob provides input settings.

Description of the adjustable parameters:

BP1 – The low brush floor pressure setting.

BP2 – The medium brush floor pressure setting

BP3 – The high brush floor pressure setting

BP4 – The BP4 setting is not used. (Any number input will have no effect.)

BJ9 – Jog. This is used to simulate a P1 – P3 setting and its effect on the brush pressure in real time. (This does not require an input setting.)

BUP - The ramp time required for the output signal to increase by 1 amp.

Bdn - The ramp time required for the output signal to decrease by 1 amp.

DF – Dither frequency. (Dither is an oscillation feature that eliminates slip stick in the operation of the solenoid.)

di – Display orientation

SA – Save settings

DUAL CONTROLLER “B” (MAIN SCRUB BRUSH) SETTINGS:

Turning the right control knob scrolls through the parameters listed above.

Turning the left control knob changes the settings of each parameter.

The settings are saved by turning the right control knob to SA and rotating the left control knob one full turn (in either direction).

To turn on the controller first turn on the ignition key but do not start the engine.

Note: in the next step stay clear of the scrub head as the sub head will lower to the floor.

Turn on the scrub head switch and the green switch.

Set BP1 to 1.52 A Providing 200 lbs of main brush pressure against the floor (415 psi at port BLB)

Set BP2 to 1.75 A Providing 300 lbs of main brush pressure against the floor (730 psi at port BLB)

Set BP3 to 1.98 A Providing 400 lbs of main brush pressure against the floor (865 psi at port BLB)

BP4 – 0.00 A

Set BUP to 00.5 SEC

Set BDN to 00.5 SEC

Set Df (dither) to 60 Hz

dl = screen orientation – no setting should be required.

SA (save settings) – Turn the left control knob one full turn (in either direction).

Turn off the green switch.

Start and run the engine at high rpm. This will raise the scrub head.

Turn off the engine.

SIDE SCRUB HEAD:

Note: the following 12 steps are required only for the factory or if you are replacing the reduction valve 730702 in port 4.2. If the part number on the side of the reduction valve body (not the coil but the cartridge body) ends with the number 45 then it is already set at 450 psi and the following 12 steps can be skipped.

Before the side scrub head floor pressure adjustment can be performed the reduction valve at the SSB hydraulic manifold port 4.1 must be adjusted to 450 psi (The purpose of this valve is to change the variable inlet pressure (approximately 700 psi) to a constant output pressure of 450 psi which is applied to the piston-end of the side scrub head lift cylinder. 450 psi is the pressure required to raise the scrub head at full engine rpm).

If the part number on the side of the reduction valve body in port 4.2 (not the coil but the cartridge body) ends with the number 45 then it is already set at 450 psi. If this valve has already been adjusted go to “Setting the side scrub brush floor pressure controller”.

To adjust the reduction valve in the SSB manifold at port 4.2:

1. Install a tee fitting with a gauge port between the hydraulic hose and the SSB hydraulic manifold at port SBLB.
2. Attach a suitable hydraulic pressure gauge to the gauge port in the tee fitting.
3. Zero the pressure gauge if necessary.
4. Loosen the lock nut on the adjustment stud on the reduction valve located on the SSB hydraulic manifold at port 4.2
5. Ensure that the green “One-Touch” switch is in the off position.
6. Start the engine
7. Set the throttle switch to high.
8. Turn the reduction valve adjustment stud clockwise until the pressure gauge reads 450 psi.
9. Tighten the reduction valve locknut.
10. Verify the pressure reading.
11. Turn off the engine.
12. Replace the hydraulic hose at port SBLB.

Setting the side scrub brush floor pressure (Using the dual proportional valve driver)

The dual floor brush pressure controller or dual proportional valve driver (located on the left front face of the operator console) provides three separate side brush floor pressure forces by controlling the hydraulic pressure output of the proportional reduction valve located on the SSB hydraulic manifold at port 6.2. This variable output pressure is applied to the piston-end of the side scrub head lift cylinder. This variable pressure is balanced against the steady 450 psi on the rod-end of the cylinder (provided by the reduction valve in port 4.2) to achieve the desired side scrub brush floor pressure.

The controller has a left control knob, a right control knob, and an information screen.

The right control knob scrolls between the various parameters.

The left control knob provides input settings.

Description of the side scrub brush pressure settings (Using the dual proportional valve driver):

The dual controller uses an “A” prefix for the optional side brush settings and a “B” prefix for the Main brush settings.

AP1 – The low side brush floor pressure setting.

AP2 – The medium side brush floor pressure setting

AP3 – The high side brush floor pressure setting

AP4 – The P4 setting is not used. (Any number input will have no effect.)

AJ9 – Jog. This is used to simulate a AP1 – AP3 setting and its effect on the side brush pressure in real time. (This does not require an input setting.)

AUP - The ramp time required for the output signal to increase by 1 amp.

Adn - The ramp time required for the output signal to decrease by 1 amp.

dF – Dither frequency. (Dither is an oscillation feature that eliminates slip stick in the operation of the solenoid.)

di – Display orientation

SA – Save settings

DUAL CONTROLLER “A” (SIDE SCRUB BRUSH) SETTINGS:

Turning the right control knob scrolls through the parameters listed above.

Turning the left control knob changes the settings of each parameter.

The settings are saved by turning the right control knob to SA and rotating the left control knob one full turn (in either direction).

To turn on the controller first turn on the ignition key but do not start the engine.

Note: in the next step stay clear of the scrub head as the sub head will lower to the floor.

Turn on the scrub head switch and the green switch.

Set AP1 to 1.60 A Providing 120 lbs of brush pressure against the floor

Set AP2 to 1.70 A Providing 130 lbs of brush pressure against the floor

Set AP3 to 1.85 A Providing 140 lbs of brush pressure against the floor

AP4 – 0.00 A

Set AUP to 00.5 SEC

Set ADN to 00.5 SEC

Set Df (dither) to 60 Hz

dl = screen orientation – no setting should be required.

SA (save settings) – Turn the left control knob one full turn (in either direction).

CMK 10-28-2013

NAUTILUS MAIN BRUSH AND IMPELLER PRESSURE RELIEF ADJUSTMENTS

For assembly line personnel

These adjustments are necessary if the hydraulic manifolds are supplied with the relief valves set at zero or incorrectly set.

MAIN BRUSH PRESSURE RELIEF ADJUSTMENT:

1. Install an appropriate pressure gauge at the gauge port on the main hydraulic manifold. The gauge port (GA) is located on the left side of the manifold when viewed from the front of the machine.
2. Disconnect the electrical connection to the main brush solenoid SV3 located in the lower left manifold port 10. This will block the flow out of the manifold and force the fluid flow to go over the relief valve RV2.
3. Loosen the lock nut and unscrew the pressure adjustment screw on the pressure relief valve RV2. This will allow all of the fluid flow to pass at low pressure through the relief valve.
4. Start the machine and switch the engine throttle switch to operating (high) speed.
5. Turn on the brushes.
6. Turn the pressure relief adjustment screw in (clockwise) while monitoring the hydraulic pressure on the pressure gauge.

When the gauge reads 2500 psi (it will vary a little, and that is OK) tighten the adjustment screw lock nut and turn off the engine.

NOTE: Perform the adjustment as quickly as possible. During this set up do not run the machine for an extended period of time after the pressure relief is set as the hydraulic oil will generate excessive heat when going through the pressure relief valve.

7. Reconnect the electrical connection to the SV3 solenoid.

This completes the main brush pressure relief adjustment.

IMPELLER PRESSURE RELIEF ADJUSTMENT:

1. Install an appropriate pressure gauge at the gauge port on the impeller hydraulic manifold. The gauge port (GA) is located on the face of the manifold when viewed from the front of the machine.

In order to force the hydraulic fluid through the relief valve it is necessary to block the flow from the manifold to the impeller.

1. Remove the hydraulic hose from the outlet of the hydraulic manifold at port VF OUT located on the top of the manifold and plug (pressure tight) the fitting on the manifold and the end of the hose.
2. Loosen the lock nut and unscrew the pressure adjustment screw on the pressure relief valve RV1 located in port 9.2. This will allow all of the fluid flow to pass at low pressure through the relief valve.
3. Start the machine and switch the engine throttle switch to operating (high) speed.
4. Turn on the impeller.
5. Turn the pressure relief adjustment screw in (clockwise) while monitoring the hydraulic pressure on the pressure gauge.

When the gauge reads 2500 psi (it will vary a little, you will probably not get it to read exactly 2500 and that is OK) tighten the adjustment screw lock nut and turn off the engine.

NOTE: Perform the adjustment as quickly as possible. During this set up do not run the machine for an extended period of time after the pressure relief is set as the hydraulic oil will generate excessive heat when going through the pressure relief valve.

6. Reconnect the hydraulic hose to the impeller solenoid.

This completes the main brush pressure relief adjustment.

11-13-2013 CMK

NAUTILUS SCRUB BRUSH FLOOR PRESSURE ADJUSTMENT

Note: the following 12 steps are required only for the factory or if you are replacing the reduction valve 730702 in port 4.1. If the part number on the side of the reduction valve body (not the coil but the cartridge body) ends with the number 45 then it is already set at 450 psi and the following 12 steps can be skipped.

Before the scrub head floor pressure adjustment can be performed the reduction valve at the main hydraulic manifold port 4.1 must be adjusted to 450 psi (The purpose of this valve is to change the variable inlet pressure (approximately 700 psi) to a constant output pressure of 450 psi which is applied to the piston-end of the scrub head lift cylinder. 450 psi is the pressure required to raise the scrub head at full engine rpm).

If this valve has already been adjusted go to “Setting the scrub brush floor pressure controller”.

To adjust the reduction valve at port 4.1:

1. Install a tee fitting with a gauge port between the main hydraulic hose and the hydraulic manifold at port BLA.
2. Attach a suitable hydraulic pressure gauge to the gauge port in the tee fitting.
3. Zero the pressure gauge if necessary.
4. Loosen the lock nut on the adjustment stud on the reduction valve located on the main hydraulic manifold at port 4.1
5. Ensure that the green “One-Touch” switch is in the off position.
6. Start the engine
7. Set the throttle switch to high.
8. Turn the reduction valve adjustment stud clockwise until the pressure gauge reads 450 psi. *(Note: It is not possible to attain 450 psi if the restrictor orifice fitting is not installed at the power steering unit pressure port.)*
9. Tighten the reduction valve locknut.
10. Verify the pressure reading.
11. Turn off the engine.
12. Replace the hydraulic hose at port BLA.

Setting the scrub brush floor pressure controller (proportional valve driver)

The floor brush pressure controller or proportional valve driver (located on the left front face of the operator console) provides three separate brush floor pressure forces by controlling the hydraulic pressure output of the proportional reduction valve located on the main hydraulic manifold at port 6.1. This variable output pressure is applied to the rod-end of the scrub head lift cylinder. This variable pressure is balanced against a steady 450 psi at the piston-end of the cylinder (provided by the reduction valve) to achieve the desired scrub brush floor pressure.

The controller has a left control knob, a right control knob, and an information screen. The right control knob scrolls through the various parameters. The left control knob provides input settings.

Description of the adjustable parameters:

P1 – The low brush floor pressure setting.

P2 – The medium brush floor pressure setting

P3 – The high brush floor pressure setting

P4 – The P4 setting is not used. (Any numerical input will have no effect.)

J9 – Jog. This is used to simulate a P1 – P3 setting and its effect on the brush pressure in real time.

UP - The ramp time required for the output signal to increase by 1 amp.

dn - The ramp time required for the output signal to decrease by 1 amp.

dF – Dither frequency. (Dither is an oscillation feature that eliminates slip stick in the operation of the solenoid.)

di – Display orientation

SA – Save settings

CONTROLLER SETTINGS:

Turning the right control knob scrolls through the parameters listed above.

Turning the left control knob changes the settings of each parameter.

The settings are saved by turning the right control knob to SA and then rotating the left control knob one full turn (in either direction).

To turn on the controller first turn on the ignition key but do not start the engine.

Note: In the next step stay clear of the scrub head as the scrub head will lower to the floor.

Turn on the scrub switch and the green switch.

Set P1 to 1.75 A This will provide 200 lbs of brush pressure against the floor (415 psi at port BLB)

Set P2 to 1.95 A This will providing 300 lbs of brush pressure against the floor (730 psi at port BLB)

Set P3 to 2.18 A This will provide 400 lbs of brush pressure against the floor (865 psi at port BLB)

P4 – Not used

Set UP to 00.5 SEC

Set DN to 00.5 SEC

Set Df (dither) to 60 Hz

dl = screen orientation – no setting should be required.

SA (save settings) – Turn the left control knob one full turn (in either direction).

Turn off the green switch.

Start and run the engine at high rpm. This will raise the scrub head.

Turn off the engine.

CMK 10-28-2014

Adjusting the Nautilus HD lift arms

CMK 11-4-2015

This sheet indicates how to correctly adjust the Nautilus HD hopper and hopper lift arm cylinders

When installing the upper clevises onto the bumper and hopper lift cylinders it is important, in order not to cause the clevis to contact and cut into the lift arms, to screw the clevis onto the threaded rod of the cylinder until the end of the cylinder rod sticks out 1/8 inch beyond the top of the clevis base. This initial setting will be finally adjusted after the lift arms are operational.

When the machine is operational:

With the bumper and hopper lift arms fully raised:

1. Adjust the hopper lift cylinder upper clevis so that the hopper dump door, when open, is 61-1/2 inches above the floor.
2. Adjust the bumper lift cylinder upper clevis so that the bumper lift arm stops just before it contacts the hopper lift arms.
3. Tighten the clevis locking bolts.

NAUTILUS HIGH DUMP CONTROLS AND OPERATION

CMK 7-5-2016

BASIC SYSTEM OPERATION:

The high dump incorporates two separate lift arm assemblies. The rear squeegee and rear bumper is attached to the outer lift arm assembly and the hopper is attached to the inner lift arm assembly.

The Nautilus high dump controls consist of three rocker switches. They are located on the left side of the operator console.

The left switch controls raising, hold, and lowering of the rear bumper.

Pressing and holding the front of the left switch raises the bumper, releasing the switch holds the bumper in the raised position, and pressing and holding the rear of the switch lowers the bumper.

The center switch controls raising, hold, and lowering of the hopper.

Pressing and holding the front of the center switch raises the hopper, releasing the switch holds the hopper in the raised position, and pressing and holding the rear of the switch lowers the hopper.

Both the bumper and hopper may be raised and lowered at the same time.

The right switch opens the hopper door when emptying the contents of the hopper.

Pressing and holding the front of the right switch for approximately 3 seconds opens the hopper door. It is not necessary to press the hopper door switch for scrubbing operations. The hopper door is automatically opened when scrubbing.

When the hopper begins to raise the hopper door is automatically closed.

If the hopper is fully lowered with the hopper door closed the hopper door will automatically open.

DETAILED SYSTEM DESCRIPTION:

Each of the two lift arm assemblies has its own hydraulic cylinder and a safety tube.

The hydraulic cylinders are used not only to raise the bumper and hopper but also to lower the bumper and hopper. Because the bumper and hopper centers of gravity, when lowered, are in front of the lift arm pivot points they will not fully retract due to gravity alone so the hydraulic cylinders are used to fully retract them.

The safety tubes include a pin that can be inserted at three different lift arm heights; low "maintenance" position, medium height position, and fully raised position.

Note: The hydraulic cylinder that powers the bumper/squeegee lift arm assembly is located on the left side of the vehicle while its safety tube is located on the right side of the vehicle.

The hydraulic cylinder that powers the hopper lift arm assembly is located on the right side of the vehicle while its safety tube is located on the left side of the vehicle.

The rear bumper and squeegee can be raised separately from the debris hopper. This is particularly useful when inspecting or performing maintenance on the rear squeegee. If desired both of the lift arm assemblies can be raised and lowered at the same time.

The outer (bumper) lift arm assembly is equipped with a solenoid-operated latch located in the lower end of the right lift arm. This latch insures that the lift arms stay in place while traveling and during scrubbing operations.

The bumper lift arm assembly is also equipped with a tilt switch located at the lower end of the right lift arm inboard of the solenoid-operated latch. If the operator raises and then lowers the hopper without opening the dump door, the tilt switch will open the hopper dump door automatically when the hopper is within 15 degrees of fully lowered.

An "interference" switch is located on the lower end of the inner (hopper) lift arms. This switch prevents the hopper lift arms from being powered into the bumper lift arms when the bumper lift arms are not fully raised.

The left switch (bumper raise, hold, and lower switch) and the center switch (hopper raise, hold, and lower switch) are three-position, spring-to-center, rocker switches. Each has a front "raise" position, center "hold" position, and a rear "lower" position.

The right switch (hopper dump door switch) is a two-position intermittent rocker switch. It has a front "door open" position and a rear "off" position. The switch is spring loaded to the off position. There is no "door closed" position.

Operating the bumper lift:

Pressing and holding the front of the left switch (bumper switch) causes the solenoid-operated latch to release the bumper lift arms and raises the bumper lift arms.

The bumper can be raised to its full height or it can be stopped at any desired height by releasing the switch. A pilot-operated check valve holds the lift arm assembly in place when raised.

Pressing and holding the rear of the left switch lowers the bumper lift arms.

Operating the hopper lift:

Pressing and holding the front of the center switch (hopper raise and lower switch) raises the hopper after a four second delay. During this delay the hopper dump door closes. This is automatic and prevents debris from falling out when the hopper is raised.

The hopper can be raised to its full height or it can be stopped at any desired height by releasing the switch. A pilot-operated check valve holds the hopper in place when raised.

Pressing and holding the rear of the center switch lowers the hopper lift arm assembly.

Opening the hopper door:

Pressing and holding the front of the right switch (hopper door open switch) for three seconds opens the hopper dump door. This switch is used only for emptying the contents of the hopper. The remaining hopper dump door operation is automatic. The dump door is always automatically opened

during scrubbing operations. Just before the hopper lift arm assembly begins to raise, the hopper dump door automatically closes. If the hopper contents are emptied (by pressing the front of the hopper open door switch) the hopper door will remain open when lowered. If the hopper is lowered without opening the hopper door the door will be automatically opened by the tilt switch.

Safety tubes and pins:

The safety pins should always be inserted into the safety tubes when working under or around the raised bumper or hopper. After raising the bumper and hopper to the desired height remove the pins from the storage tubes and insert them into the appropriate hole in the safety tubes depending on the raised height of the bumper and hopper, (low "maintenance" position, medium height position, or fully raised position).

It is not necessary to "lock" the safety pin in place by lowering the bumper or hopper onto the safety pin. If however the lift arms are lowered onto the pins relief valves will prevent the cylinders from causing any damage to the lift arms or adjacent structure.

Adjusting the Nautilus neutral sensing switch

Purpose:

Floor damage can occur by operating the scrub brushes when the vehicle not in motion.

To prevent floor damage a neutral sensing switch shuts off and raises the scrub brushes and turn off the solution flow whenever the vehicle remains motionless for more than 2 seconds.

When vehicle motion resumes the scrub brushes automatically turn on and lower and the solution flow is turned on.

Operation:

The neutral sensing switch is a normally open roller switch located below and inboard of the pump centering unit (Hydroback unit 731181).

The switch is activated by a cam attached to the pump centering arm.

Adjustment:

NOTE: Directional control (neutral) must be set before performing this adjustment.

Do not attempt to adjust the switch by bending the switch roller arm.

1. Slightly loosen the neutral switch mounting fasteners so that the switch can be repositioned by hand.

The adjustment can be monitored by listening to the sound of the switch as it opens and closes.

2. Begin the adjustment by moving the switch body so that the roller fits up into the half-round cut out in the cam. This is the neutral position and the switch should be open.

Ensure that the switch body is kept level during adjustment. If the left end of the switch body is tilted up it can cause the switch roller arm to bend during operation.

3. Adjust the switch body so that that a very small amount of pump arm motion will force the roller down and close the switch.

Quick switch activation when the vehicle moves forward is more important than when the vehicle moves in reverse so the adjustment should be made while pushing the pump arm slightly forward by hand (towards the front of the vehicle) and then releasing the arm while listening for the switch to close and open.

It is important that the switch reacts quickly otherwise it will be necessary to drive the vehicle at too high a speed before the brushes become activated.

4. Ensure that the switch also closes and opens when the pump arm is pushed slightly to the rear and released.
5. Tighten the switch fasteners and retest.

NAUTILUS DIRECTIONAL CONTROL ADJUSTMENT.

For correct operation the directional control adjustments must be made in the order shown below.

Note: Step one is necessary only when replacing the Hydroback pump centering unit 731181 or the directional control cable 730356.

1. DIRECTIONAL CONTROL CABLE INSTALLATION AND ADJUSTMENT.

At the pump-end of the directional control cable:

Install one 5/8 jam nut onto the cable jacket threads.

Slide two star lock washers up to the 5/8 jam nut.

Position the end of the directional control cable into the Hydroback unit then thread the 1/4-28 threaded rod on the end of the cable into the small end of the Hydroback unit so that the 1/4-28 threaded cable rod sticks out .31 inches from the small end of the Hydroback unit.

Thread one 1/4-28 jam nut against the face of the Hydroback unit and tighten.

Install the 1/4-28 rod end onto the end of the cable and tighten against the jamb nut.

Thread the 5/8 threaded end of the Hydroback unit onto the 5/8 threaded cable jacket.

Mount the cable/Hydroback assembly onto the Hydroback adjustment plate with one star washer located on each side of the adjustment plate.

With the Hydroback unit in the spring-centered position, slide the Hydroback mount and star washer tightly against the adjustment plate and then tighten the 5/8 jam nut.

Attach the rod end to the pump centering arm.

2. PROPULSION PUMP CENTERING (NEUTRAL) ADJUSTMENT:

With the rear wheel raised off of the floor and the engine running at operating speed (not at idle), adjust the Hydroback adjustment plate so that the rear wheel returns to neutral (zero rotation) after fully pressing, then releasing, the directional control pedal in forward and in reverse.

3. DIRECTIONAL CONTROL CABLE INSTALLATION AND ADJUSTMENT

At the pedal-end of the cable:

Install the directional control pedal stop bolt so the top of the bolt remains clear of the movement of the directional control pedal. This bolt will be adjusted later.

Thread the 1/4 -28 rod end .38-inch onto the cable end.

Bolt the rod end to the correct side of the directional control pedal arm.

Mount the directional control cable onto the floor plate and adjust the 5/8 jam nuts so that the heel of the directional control pedal is .75-inch above the floor. This will provide the correct forward and reverse vehicle speeds and optimum pedal angle. This adjustment may require that the threaded portion of the cable jacket is as far forward as possible in the mounting tab under the floor plate. If more adjust is necessary that can be made at the floor mounting tab, reposition the rod end but do not allow less than 5/15-inch engagement of the cable end into the rod end.

NOTE: Adjusting the angle of the directional control pedal as shown above will not affect the neutral adjustment setting of the Hydroback unit or the propulsion pump.

4. DIRECTIONAL CONTROL PEDAL STOP BOLT:

Adjust the stop bolt (located below the front of the directional control pedal) so that the pedal motion in forward is halted just as or just before the pump control arm reaches its maximum forward position (the built in stop inside the propulsion pump). The stop bolt will prevent damage to the directional control system if an operator stands on or otherwise abuses the directional control pedal.

5. NEUTRAL AND REVERSE SENSING SWITCHES:

Install and adjust the neutral and reverse sensor switches.

CMK 10-28-2014

Adjusting the Nautilus reverse sensing switch

Purpose:

The lowered rear squeegee can be damaged by being forced into the floor when the vehicle is moving in reverse.

To prevent squeegee damage a reverse sensing switch causes the rear squeegee to raise whenever the vehicle moves in reverse.

When the vehicle is stopped or resumes forward motion the rear squeegee automatically lowers back to the floor

Operation:

The neutral sensing switch is a whisker-type switch located below the directional control pedal.

The switch is activated by the directional control pedal arm.

Adjustment:

NOTE: the heel end of the directional control pedal, when in neutral, must be set to 3/4 inch above the operator compartment floor before performing this adjustment.

1. Slightly loosen the neutral switch mounting fasteners so that the switch can be repositioned by hand.

The adjustment can be monitored by listening to the sound of the switch as it opens and closes.

2. Adjust the switch body so that that the switch is already activated when the directional control pedal is in neutral and stays activated when the pedal is pushed in the forward direction. The switch should close immediately upon moving the pedal into the reverse direction. It is important that only a very small amount of reverse pedal movement is required to close the switch.

It is important that the switch reacts quickly in reverse otherwise the rear squeegee will not raise when moving the vehicle in reverse at low speed.

3. Ensure that the switch activates correctly when the directional control pedal is pushed slightly forward and released and when pushed slightly in reverse and released.
4. Tighten the switch fasteners and retest.